

Control of an Electro-Hydraulic Drive using PD-PI, PI-PD and 2DOF-2 Controllers Compared with PID Controller

Galal Ali Hassaan

Department of Mechanical Design & Production, Faculty of Engineering,
Cairo University, Giza, Egypt
Email: galalhassaan@ymail.com

Abstract:

This paper investigates the tuning of PD-PI, PI-PD and 2DOF-2 controllers when used to control an electro-hydraulic drive. The controllers are tuned using MATLAB optimization toolbox and the ITAE performance indices. The tuning results are presented and applied to generate the unit step time response for both reference and disturbance inputs. A novel technique is used to improve the disturbance rejection associated with the proposed controllers. The characteristics of the step time responses are compared with those of a PID controlled from previous work and presented in graphical and tabulated form. The best controller for both reference and disturbance inputs is assigned.

Keywords — Electro-hydraulic drive, PD-PI controller tuning, PI-PD controller tuning, 2DOF-2 controller tuning.

I. INTRODUCTION

Electro-hydraulic drives have wide applications in industry, loaders, excavators, cranes and airplanes. They provide high output forces and torques and large strokes. They require good controllers/compensators to control their outputs with good performance characteristics. This is the goal of the present research work focusing on controllers from the second generation of PID controllers. Here are some of the research efforts regarding this subject:

Pastakuljic (1995) addressed issues related to the design and model identification of an advanced hydraulic system. He derived a nonlinear model giving good correspondence with experimental data. He obtained the transfer function of the electro-hydraulic dynamic system between the piston position and the valve spool position as a second order model with integrator. He analyzed the control of the electric motor using a PI-controller and found the transfer function for its speed control [1]. Rahmat, Rozali, Abdul Wahab and Jusoff (2010) modeled an electro-hydraulic control system using process identification techniques in MATLAB. They designed a PID controller for SIMULINK application and tuned the PID controller using Ziegler-Nichols method. They derived the process model in a digital form and

presented its step time response and the step response of the control system using the tuned PID controller in the time and frequency domain [2]. Aly (2012) investigated the model reference PID control of an electro-hydraulic crane drive. He used a standard second-order model for the controlled hydraulic system and provided step time response for the crane using the nonlinear model of the drive and a linearized model. The PID controllers used were tuned using the MATLAB optimization toolbox for different natural frequency and unit damping ratio [3].

Basmenj, Sakhavati and Gafuri (2014) used a PID controller to control an electro-hydraulic actuator. They tuned the parameters of the PID controller using the Imperialist Competitive Algorithm and a fitness function for optimization feedback. They presented the step time response of the control system without numerical values for the resulting maximum overshoot, settling time and steady-state error [4]. Sokolova, Krol, Tavanuk and Sokolov (2015) derived the nonlinear model of an electro-hydraulic drive, linearized it and presented the block diagram of its control system between a reference input signal and its output position showing the location of the disturbance loading. They presented also the block diagram of the linearized dynamic system for both reference and disturbance inputs [5]. Smakwong and Assawinchaichote (2016) used the

genetic algorithm to tune a PID controller for the control of an electro-hydraulic servo valve system. They compared with other tuning techniques: Ziegler-Nichols, automatic tuning and particle swarm optimization. They used a 2/5 transfer function model for the controlled system [6].

Liu, Li and Shen (2017) adaptively identified closed-loop system of an electro-hydraulic servo system using a recursive extended least squares algorithm. They presented block diagrams for the displacement control system and force control system and acceleration controller [7]. Alfina, Astharini, Gandena and Lubis (2018) focused on the analysis of a commercially developed hydraulic servo and the tuning of PI controller using PI-fuzzy logic controller method. They modeled the analyzed Vickers servo valve and provided its transfer function having 0/3 order [8].

Sokolov, Krol, Romanchenkakhalamov and Baturin (2020) developed the mathematical model of a rotary motion electro-hydraulic drive. They compared the experimental and analytical transient time responses for the shaft angular motion velocity [9]. Atsari and Abdul Halim (2021) developed a fractional order PID controller to reduce maximum overshoot and steady-state error in electro-hydraulic actuator control. They compared with a conventional PID controller tuned using Ziegler-Nichols technique. They claimed that the fractional order PID controller reduced the maximum overshoot of the actuator output by 17.6 % and the steady-state error by 0.5 % [10].

Ma, Gu, Xu, Shi and Wang (2022) proposed a fuzzy PID control with load force compensation for asymmetric electro-hydraulic servo system based on improved PSO optimization. They derived the mathematical model of the actuator and linearized it. They claimed that their proposed controller revealed optimum dynamic performance and minimum steady-state error [11]. Xiao, Li, Liu and Tan (2023) derived the mathematical model of an electro-hydraulic servo system used in a drill pipe handling system and obtained its transfer function. They used an improved particle swarm optimization to tune a PID controller to control the piston position of the electro-hydraulic drive compared with classical PSO technique. They used a 0/4 transfer function with an integrator for the electro-hydraulic

drive [12]. Jianying, Weidong, Heng and Lingbing (2024) classified the improved PID controller applied to electro-hydraulic servo systems into three categories: PID parameters tuning, PID parameters online adjustment and compound control strategy with PID algorithm. They compared the approach of the three techniques and concluded that the combination of the three techniques provided high control accuracy and robustness and fast response speed [13].

II. THE CONTROLLED PROCESS

The controlled process is an electro-hydraulic drive having a 2/5 transfer function model, $G_p(s)$ given by [6]:

$$G_p(s) = (25.2s^2 + 22.2s + 3) / (s^5 + 16.6s^4 + 25.41s^3 + 17.2s^2 + 12s + 1) \quad (1)$$

To assign the duties of the proposed controllers we have to have a look into the step time response of electro-hydraulic drive under control. Eq.1 is used to plot this unit-step time response using the MATLAB command 'step' [14] which is shown in Fig.1.

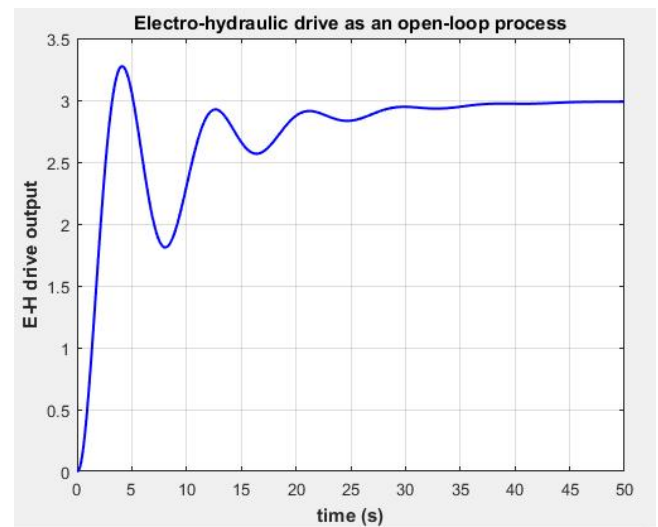

Fig.1 Step time response of the electro-hydraulic drive

Fig.1 reveals the following dynamic characteristics of the electro-hydraulic drive under study:

- Maximum overshoot: 9.13 %
- Settling time: 34.36 s
- Steady-state error: -2

Any proposed controller has to overcome those challenges and provide step response without any

overshoot and steady-state error and with fast time response.

III. ELECTRO-HYDRAULIC DRIVE CONTROL USING A PD-PI CONTROLLER

- The PD-PI controller is one of the second generation controllers introduced by the author starting from 2014 to replace the first generation of PID controllers. The author used PD-PI control to control a variety of industrial processes with bad dynamics such as: highly oscillating second-order process [20], integrating plus time delay process [21], delayed double integrating process [22], overdamped second-order processes [23], fourth-order blending process [24], coupled dual tanks [25], internal humidity of a greenhouse [26], rocket pitch angle [27], liquefied natural gas tank pressure [28] and liquefied natural gas tank level [29]
- The two elements of the PD-PI controller (PD and PI control modes) are set in cascade in the forward path of the block diagram of the boiler-drum level control system just after the error detector.
- The transfer function of the PD-PI controller is given by [21]:

$$G_{PDPI}(s) = [K_d K_{pc2} s^2 + (K_{pc1} K_{pc2} + K_d K_i) s + K_{pc1} K_i] / s \quad (2)$$

Where:

- K_{pc1} = proportional gain of the PD-control mode
- K_d = derivative gain of the PD-control mode
- K_{pc2} = proportional gain of the PI-control mode
- K_i = integral gain of the PI-control mode
- The controller has four gain parameters which have to be tuned for optimum performance for reference track input and good performance for the purpose of disturbance rejection.
- The unit step time response of the control system, $c(t)$ for a reference input is obtained using the closed loop transfer function derived from the block diagram of the control system with zero disturbance and the 'step' command of MATLAB [14].

- An error signal $e(t)$ of the control system for a unit step input is assigned as: $1 - c(t)$ for a control system with unit feedback elements.
- The ITAE performance index [25] is minimised using the MATLAB optimization toolbox [26].
- Minimizing the error function ITAE reveals the optimal gain parameters of the controller.
- The PD-PI controller tuning technique reveals the following tuned controller parameters:

$$\begin{aligned} K_{pc1} &= 0.3238487 & ; & & K_d &= 1.5708527 \\ K_{pc2} &= 0.3065738 & ; & & K_i &= 1.0262239 \end{aligned} \quad (3)$$

- The unit step time response of the control system for reference and disturbance inputs as generated by the MATLAB command 'plot' [14] using the PD-PI controller tuned gain parameters in Eq.3 and its transfer functions is shown in Fig.2.

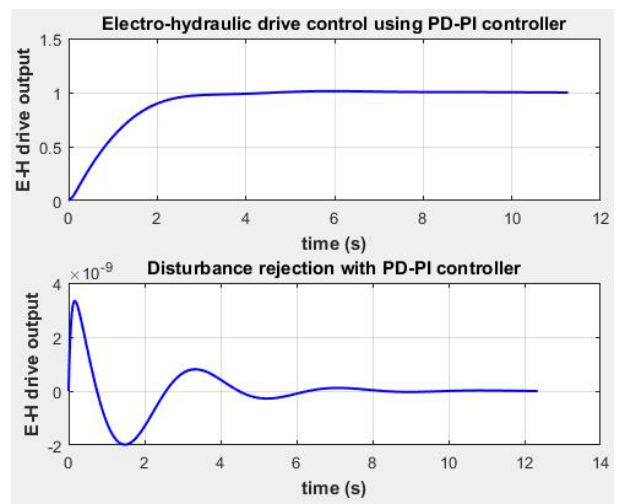

Fig.2 Step time response of the PD-PI controlled electro-hydraulic drive.

COMMENTS:

- For the reference input tracking step time response:
 - ✚ Maximum percentage overshoot: 1.319 %
 - ✚ Settling time: 3.23 s
- For disturbance rejection using the tuned PD-PI controller:
 - ✚ Maximum step time response: 3.33×10^{-9}
 - ✚ Time of maximum step time response: 0.17 s

- ✚ Minimum step time response: -1.98×10^{-9}
- ✚ Settling time (with filter): 10 s

IV. ELECTRO-HYDRAULIC DRIVE CONTROL USING A PI-PD CONTROLLER

- The PI-PD controller is one of the second generation controllers introduced by the author starting from 2014 to replace the first generation PID controllers. The author used PI-PD control to control a variety of industrial processes with bad dynamics such as: highly oscillating second-order process [27], third-order process [28], greenhouse humidity [21], fourth-order blending process [23], boost-glide rocket engine [29] and BLDC motor [30], blending process [31] and boiler drum water level [32].
- The block diagram of a control system incorporating a PI-PD controller controlling the boiler-drum water level is shown in Fig.3 [27].

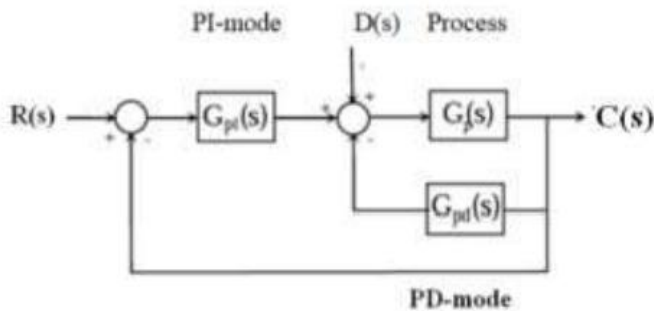

Fig.3 Block diagram of PI-PD controlled process [27].

- The PI-PD controller is composed of two elements: PI-control-mode in the forward path receiving its input from the error detector of the control system and a PD-control-mode in the feedback path of an internal loop with the controlled process.
- The PI-PD controller elements have the transfer functions:

$$G_{PI}(s) = K_{pc1} + (K_i/s)$$

And $G_{PD}(s) = K_{pc2} + K_d s$ (3)

- K_{pc1} , K_i , K_{pc2} and K_d are the four controller parameters gains to be tuned to adjust the performance of the closed-loop control system.

- The transfer functions of the closed-loop control system in Fig.3 are derived from the block diagram using Eqs.1 for the process and 3 for the PI-PD controller for both inputs $R(s)$ and $D(s)$.
- The unit step time response of the control system, $c(t)$ for a reference input is obtained using the closed loop transfer function derived from the block diagram of the control system with zero disturbance and the 'step' command of MATLAB [14].
- An error signal $e(t)$ of the control system for a unit step input is assigned as: $1 - c(t)$ for a control system with unit feedback elements.
- The ITAE performance index [25] is minimised using the MATLAB optimization toolbox [26].
- Minimizing the error function ITAE reveals the optimal gain parameters of the PI-PD controller.
- The PI-PD controller tuning technique reveals the following tuned controller parameters:

$$K_{pc1} = 10.59482 ; K_i = 1.27367$$

$$K_{pc2} = 0.838405 ; K_d = 9.86011 \quad (4)$$

- The unit step time response of the control system for reference and disturbance inputs as generated by the MATLAB command 'plot' [14] using the PI-PD controller tuned gain parameters in Eq.4 and shown in Fig.4.

COMMENTS:

- For the reference input tracking step time response:
 - ✚ Maximum percentage overshoot: zero
 - ✚ Settling time: 3.73 s
- For disturbance rejection using the tuned PI-PD controller:
 - ✚ Maximum step time response: 2.145×10^{-9}
 - ✚ Time of maximum step time response: 0.07 s
 - ✚ Minimum step time response: -0.707×10^{-9}
 - ✚ Settling time (with using filter): 2.5 s

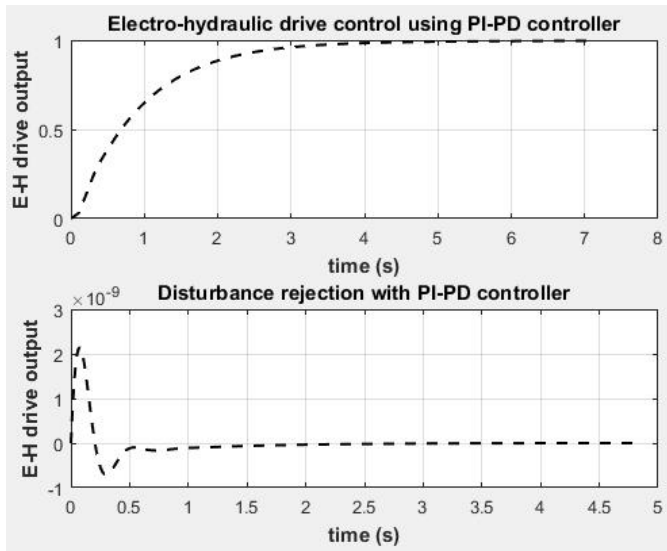

Fig.4 Step time response of the PI-PD controlled electro-hydraulic drive.

V. ELECTRO-HYDRAULIC DRIVE CONTROL USING A 2DOF-2 CONTROLLER

- The 2DOF controller is one of the second generation controllers introduced by the author starting from 2014 to replace the first generation PID controllers. The author used different structures of 2DOF control to control a variety of industrial processes with bad dynamics such as: liquefied natural gas pressure control [23], liquefied natural gas level control [24], boost-glide rocket engine [29], BLDC motor control [30], boiler-drum water level [32], highly oscillating second-order process [33], delayed double integrating processes [34], second-order-like processes [35], furnace temperature [36] and gas turbine speed [37].
- The block diagram of a control system incorporating a 2DOF-structure 2 controller (denoted as 2DOF-2) proposed to control the electro-hydraulic drive is shown in Fig.5 [38].
- The 2DOF-2 controller is composed of two elements: PI-control-mode of $G_{c1}(s)$ transfer function in a feedforward loop starting from the reference input and providing the control signal to the controlled process and a PID-control mode of $G_{c2}(s)$ transfer function in

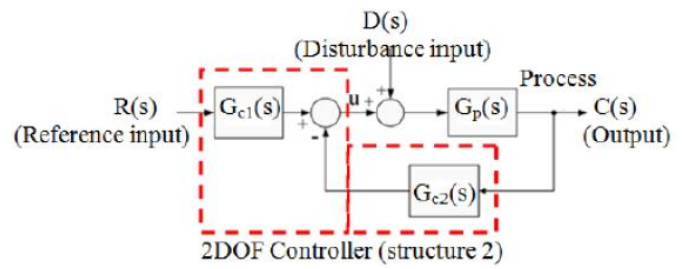

Fig.5 Block diagram of 2DOF-2 controlled process [38].

- The 2DOF-2 controller elements have the transfer functions:

$$G_{c1}(s) = K_{pc1} + (K_i/s)$$

And $G_{c2}(s) = K_{pc2} + (K_i/s) + K_d s$ (5)

- K_{pc1} , K_i , K_{pc2} and K_d are the four controller parameters gains to be tuned to adjust the performance of the closed-loop control system.
- The transfer functions of the closed-loop control system in Fig.5 are derived from the block diagram using Eqs.1 for the process and 5 for the 2DOF-2 controller for both inputs $R(s)$ and $D(s)$.
- The unit step time response of the control system, $c(t)$ for a reference input is obtained using the closed loop transfer function derived from the block diagram of the control system with zero disturbance and the 'step' command of MATLAB [14].
- An error signal $e(t)$ of the control system for a unit step input is assigned as: $1 - c(t)$ for a control system with unit feedback elements.
- The ITAE performance index is minimised using the MATLAB optimization toolbox [26].
- Minimizing the error function ITAE reveals the following optimal gain parameters of the 2DOF-2 controller:
 $K_{pc1} = 20.67048$; $K_i = 25.28815$
 $K_{pc2} = 27.60424$; $K_d = 6.65956$ (6)
- The unit step time response of the control system for reference and disturbance inputs as generated by the MATLAB command 'plot' [14] using the 2DOF-2 controller tuned gain parameters in Eq.6 and shown in Fig.6.

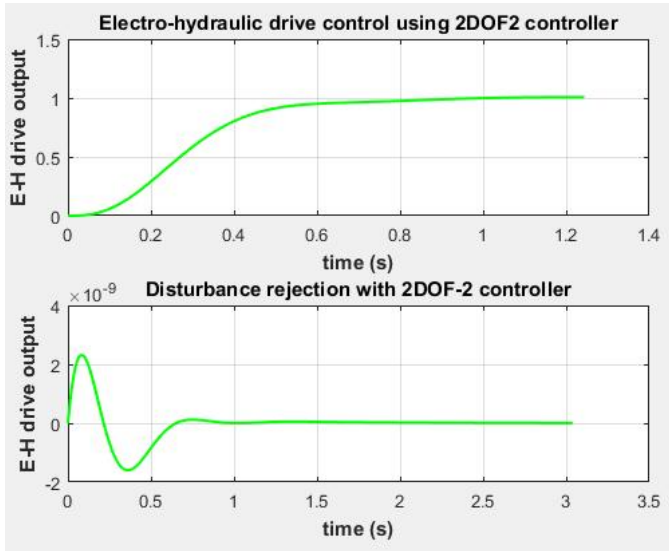

Fig.6 Step time response of the 2DOF-2 controlled electro-hydraulic drive.

COMMENTS:

- For the reference input tracking step time response:
 - ✚ Maximum percentage overshoot: zero
 - ✚ Settling time: 0.83 s
- For disturbance rejection using the tuned PID controller:
 - ✚ Maximum step time response: 2.313×10^{-9}
 - ✚ Time of maximum step time response: 0.08 s
 - ✚ Minimum step time response: -1.598×10^{-9}
 - ✚ Settling time (with using filter): 1 s

VI. COMPARISON OF TIME BASED CHARACTERISTICS

- Graphical comparison for both reference and disturbance inputs: Presented in Figs.7 and 8.
- Numerical comparison for the time-based characteristics of the step time response for reference input and disturbance input of the control system with the three investigated controllers (PD-PI, PI-PD and 2DOF-2) proposed in this work to control the electro-hydraulic drive is presented in Tables 1 and 2 with comparison with the application of a PID controller to control the same process with its parameters tuned using genetic algorithm [6].

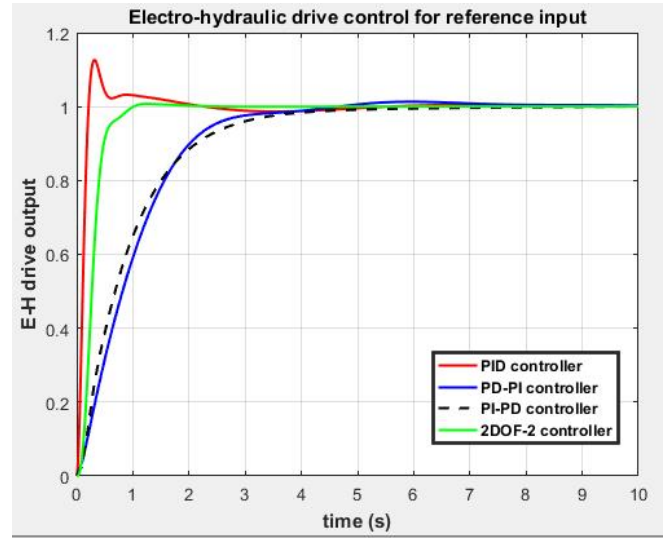

Fig.7 Step reference input time response comparison for electro-hydraulic drive control.

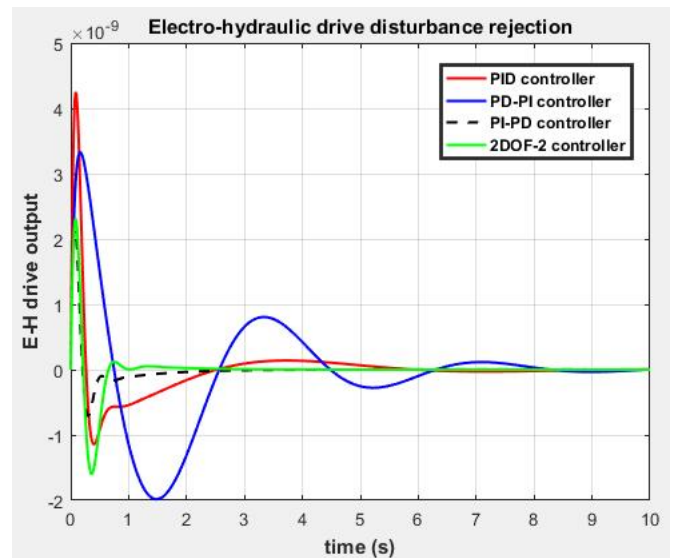

Fig.8 Step disturbance input time response comparison for electro-hydraulic drive control.

TABLE 1
TIME-BASED CHARACTERISTICS FOR REFERENCE INPUT TRACKING

| Controller | PID [6] | PD-PI | PI-PD | 2DOF-2 |
|-----------------------|---------|-------|-------|--------|
| Maximum overshoot (%) | 12.622 | 1.319 | 0 | 0 |
| Settling time (s) | 2.278 | 3.230 | 3.73 | 0.83 |

TABLE 2
TIME-BASED CHARACTERISTICS WITH
DISTURBANCE INPUT REJECTION

| Controller | PID [6] | PD-PI | PI-PD | 2DOF-2 |
|-----------------------------------|-------------------------|-------------------------|--------------------------|--------------------------|
| Maximum time response | 4.25 x10 ⁻⁹ | 3.33x10 ⁻⁹ | 2.145x10 ⁻⁹ | 2.313 x10 ⁻⁹ |
| Time of maximum time response (s) | 0.17 | 0.17 | 0.07 | 0.08 |
| Minimum time response | -1.14 x10 ⁻⁹ | -1.98 x10 ⁻⁹ | -0.707 x10 ⁻⁹ | -1.598 x10 ⁻⁹ |
| Settling time to zero (s) | 7 | 10 | 2.5 | 1 |

VII. CONCLUSIONS

- The research work presented in this research paper handled the tuning of PD-PI, PI-PD and 2DOF-2 controllers used to control an electro-hydraulic drive.
- The controlled process was a stable one with bad dynamics: high maximum overshoot (9.13 %), slow process (34.3 s settling time) and high steady-state error (-2) putting more challenges of the proposed controllers.
- The three controllers were tuned using the MATLAB optimization toolbox with an ITAE performance indices aiming at providing a good dynamic performance for the control system.
- The three proposed controllers were compared with PID controller tuned by a genetic algorithm [6].
- The PD-PI controller succeeded to reduce the maximum percentage overshoot to only 1.319 % compared with 12.62 % for the PID controller but it was not the best controller regarding the reference input tracking.
- The PI-PD controller succeeded to eliminate completely the maximum percentage overshoot but it provided a settling time of 3.75 s compared with 2.278 s for the PID controller. It was not the best controller among the four controllers investigated in this research work.

- The 2DOF controller was selected as the best controller regarding reference input tracking based on maximum overshoot and settling time. It succeeded to eliminate completely the maximum overshoot and reduce the settling time to only 0.83 s which is the minimum settling time compared with all the other analyzed controllers.
- Regarding disturbance rejection, again the 2DOF-2 controller proved that it is the best selection to control the electro-hydraulic drive process since it allowed the step time response due to disturbance input to settled only within 1 second compared with 7 s for the PID controller.
- Regarding disturbance rejection, the PI-PD controller comes after the 2DOF-2 controller.

REFERENCES

1. V. Pastrakuljic, "Design and modeling of a new electro hydraulic actuator", M. Sc. Thesis, Mechanical Engineering Department, University of Toronto, Canada, 1995.
2. M. Rahmat, S. Rozali, A. Abdul Wahab and K. Jusoff, "Modelling and control design of an electro-hydraulic actuator system", *American Journal of Applied Sciences*, vol.7, issue 8, pp.1106-1108, 2010.
3. A. A. Aly, "Model reference PID control of an electro-hydraulic drive", *International Journal of Intelligent Systems and Application*, vol.11, pp.24-32, 2012.
4. A. Basmenj, A. Sakhavati and J. Ghafuri, "PID controller design for position control of electro-hydraulic actuators using imperialist competitive algorithm", *Indian Journal of Scientific Research*, vol1, issue 1, 775-779, 2014.
5. Y. Sokolova, O. Krol, T. Tavanuk and V. Sokolov, "Transfer functions of the automatic electrohydraulic drive", *TEKA Commission of Motorization and Energetics in Agriculture*, vol.15, issue 2, pp.3-8, 2015.
6. T. Smakwong and W. Assawinchaichote, "PID controller design for electro hydraulic servo valve system with genetic algorithm", *Procedia Computer Science*, vol.86, pp.91-94, 2016.

7. G. Liu, G. Li and G. Shen, "Experimental evaluation of the parameter-based closed-loop transfer function identification for electro-hydraulic servo system", *Advances in Mechanical Engineering*, vol.9, issue 1, pp.1-12, 2017.
8. R. Alfina, D. Astharini, D. Gandana and A. Lubis "Modeling and analysis of a servo position control system using PI-Fuzzy logic controller method ", *International Journal of Mechanical Engineering and Technology*, vol.9, issue 12, pp.1022-1033, 2018.
9. V. Sokolov, O. Krol, O. Romanchenko, Y. Kharlamov and Y. Baturin, "Mathematical model for dynamic characteristics of automatic electrohydraulic drive for technological equipment", *Journal of Physics: Conference Series*, 1553, 7 pages, 2020.
10. E. Atsari and Abdul Halim, "Design of a fractional order PID controller for electro hydraulic actuator", *Game Technology, Information System, Computer network, Computing, Electronics and Control Journal*, vol.6, issue 1, pp.59-68, 2021.
11. Y. Ma, L. Gu, Y. Xu, L. Shi and H. Wang, "Research on control strategy of asymmetric electro-hydraulic servo system based on improved PSO algorithm", *Advances in Mechanical Engineering*, vol.14, issue 5, pp.1-14, 2022.
12. W. Xiao, G. Li, C. Liu and L. Tan, "Improved particle swarm optimization for solving in PID control of electro-hydraulic servo system", *Biomedical Journal Scientific and Technological Research*, vol.51, issue 2, pp.42447-42460, 2023
13. I. Jianying, L. Weidong, L. Heng and K. Lingbing, "Review of research on improved PID control in electro-hydraulic servo system", *Recent Patents on Engineering*, vol.18, issue 1, pp.54-68, 2024.
14. Mathworks, "Step response of dynamic system", <https://www.mathworks.com/help/ident/ref/dynamicssystem.step.html>, 2023.
15. G. A. Hassaan, "Tuning of a PD-PI controller used with a highly oscillating second-order process", *International Journal of Scientific and Technology Research*, vol.3, issue 7, pp.145-147, 2014.
16. G. A. Hassaan, "Tuning of a PD-PI controller used with an integrating plus time delay process", *International Journal of Scientific and Technology Research*, vol.3, issue 9, pp.309-313, 2014.
17. G. A. Hassaan, "Controller tuning for disturbance rejection associated with a delayed double integrating process", *International Journal of Computer Techniques*, vol.2, issue 3, pp.110-115, 2015.
18. G. A. Hassaan, "Tuning of a PD-PI controller to control overdamped second-order processes", *International Journal of Engineering and Research Publication and Reviews*, vol.2, issue 12, pp.1042-1047, 2021.
19. G. A. Hassaan, "Tuning of controllers for reference input tracking of a fourth-order blending process", *World Journal of Engineering Research and Technology*, vol.8, issue 4, pp.177-199, 2022.
20. G. A. Hassaan, "Tuning of controllers for reference input tracking of coupled-dual liquid tanks", *World Journal of Engineering Research and Technology*, vol.8, issue 2, pp.86-101, 2022.
21. G. A. Hassaan, "Tuning of PD-PI and PI-PD controllers to control the internal humidity of a greenhouse", *International Journal of Engineering Techniques*, vol.9, issue 4, 9 pages, 2023.
22. G. A. Hassaan, "Control of a rocket pitch angle using PD-PI controller, feedback first-order compensator and I-PD compensator", *International Journal of Computer Techniques*, vol.11, issue 1, 8 pages, 2024.
23. G. A. Hassaan, "Liquefied natural gas tank pressure control using PID, PD-PI and 2DOF controllers", *World Journal of Engineering Research and Technology*, vol.10, issue 2, pp.18-33, 2024.
24. G. A. Hassaan, "Liquefied natural gas tank level control using PD-PI, I-PD and 2DOF controllers", *World Journal of Engineering Research and Technology*, vol.10, issue 1, pp.13-26, 2024.
25. F. G. Martins, "Tuning PID controllers using the ITAE criterion", *International Journal of Engineering Education*, vol.21, issue 5, pp.867-873, 2005.

26. C. P. Lopez, "MATLAB optimization techniques", Apress, 2014.
27. G. A. Hassaan, "Tuning of a PI-PD controller used with a highly oscillating second-order process", *International Journal of Research and Innovative Technology*, vol.1, issue 3, pp.42-45, 2014.
28. A. Singer, G. A. Hassaan and M. Elgamil, "Tuning of a PI-PD controller used with a third-order process", *World Journal of Engineering Research and Technology*, vol.8, issue 4, pp.367-375, 2020.
29. G. A. Hassaan, "Control of a boost-glide rocket engine using PD-PI, PI-PD and 2DOF controllers", *International Journal of Research Publication and Reviews*, vol.4, issue 11, pp.913-923, 2023.
30. G. A. Hassaan, "Tuning of controllers for reference input tracking of a BLDC motor", *International Journal of Progressive Research in Engineering, Management and Science*, vol.2, issue 4, pp.5-14, 2022.
31. G. A. Hassaan, "Tuning of controllers for reference input tracking of a fourth order blending process", *World Journal of Engineering Research and Techniques*, vol.8, issue 4, 177-190, 2022.
32. G. A. Hassaan, "Control of boiler drum water level using PID, PD-PI PI-PD and 2DOF controllers", *International Journal of Engineering and Techniques*, vol.10, issue 1, 10 pages, 2024.
33. G. A. Hassaan, "Tuning of a 2DOF controller for use with a highly oscillating second-order-like process", *International Journal of Modern Trends in Engineering and Research*, vol.2, issue 8, pp.292-298, 2015.
34. G. A. Hassaan, "Controller tuning for disturbance rejection associated with delayed double integrating process, Part V: 2DOF controller", *International Journal of Engineering and Techniques*, vol.1, issue 4, pp.26-31, 2015.
35. G. A. Hassaan, "Tuning of a feedforward 2DOF PID controller to control second-order-like processes", *International Journal of Engineering and Techniques*, vol.4, issue 4, pp.135-142, 2018.
36. G. A. Hassaan, "Furnace control using I-PD, PD-PI and 2DOF controllers compared with fuzzy-neural controller", *International Journal of Computer Techniques*, vol.11, issue 2, 10 pages, 2024.
37. G. A. Hassaan, "Tuning of 2DOF controllers for the speed control of a gas turbine", *International Journal of Engineering and Techniques*, vol.8, issue 2, pp.35-44, 2022.
38. G. A. Hassaan, "Temperature control of a greenhouse using PD-PI, PI-PD and 2DOF controllers", *International Journal of Engineering Inventions*, vol.12, issue 9, pp.156-162, 2023.

DEDICATION

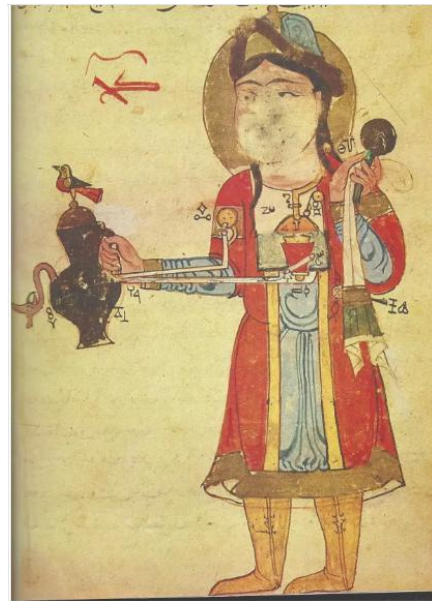

Ibn Ismail Aljazari

- Muslim Mechanical Engineer lived during the period 1136-1206 AC.
- Acted as a Chief Engineer at the ruler Palace.
- Wrote a distinguished book on ingenious mechanical devices in 1206 AC describing the design and operation of 50 mechanical devices.
- He is the father of robotics, clocks, positive displacement pumps and dynamic fountains.
- He invented single and multiple rotors working with single drive.
- He invented different designs of flow control valves.

- He used many mechanical principles and components such as: siphons, levers, crankshafts, cams, flow control valves, gears and water wheels.

BIOGRAPHY



Galal Ali Hassaan

- Emeritus Professor of System Dynamics and Automatic Control.
- Has got his B.Sc. and M.Sc. from Cairo University in 1970 and 1974.
- Has got his Ph.D. in 1979 from Bradford University, UK under the supervision of Late Prof. John Parnaby.
- Now with the Faculty of Engineering, Cairo University, EGYPT.
- Research on Automatic Control, Mechanical Vibrations, Mechanism Synthesis and History of Mechanical Engineering.
- Published more than 300 research papers in international journals and conferences.
- Author of books on Experimental Systems Control, Experimental Vibrations and Evolution of Mechanical Engineering.
- Chief Justice of the International Journal of Computer Techniques.
- Member of the Editorial Board of IJET.
- Reviewer in some international journals.
- Scholars interested in the authors publications can visit:

<http://scholar.cu.edu.eg/galal>