

# Synchronous Machines

1

## **2. Synchronous Motors**

- Phasor Diagram and Equivalent Circuit
- Power and Torque
- Motor Modes of Operation
- Motor Starting
- Motor Rating

# Synchronous Motors

# Synchronous Motors

3

At  $n = \text{zero}$ , the stator field is rotating at  $n_s$  and the rotor field is stationary ( $n = \text{zero}$ ).

The produced torque will be a pulsating torque (zero average) so the motor will not self start.

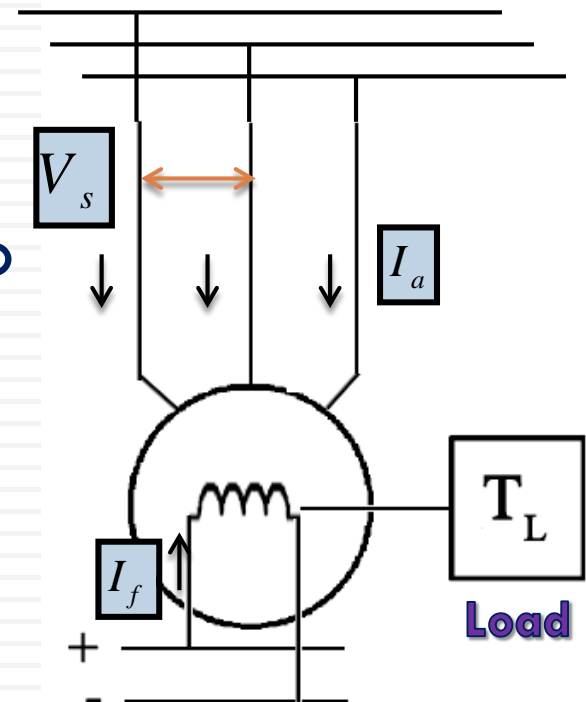

# Synchronous Motor: Equivalent Circuit

4

## Approximate Equivalent Circuit

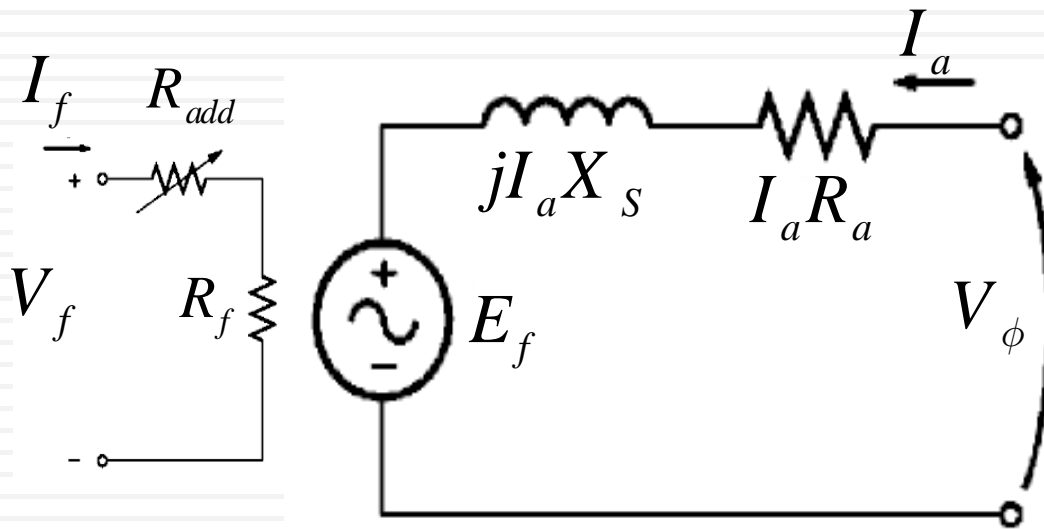

Lagging Current

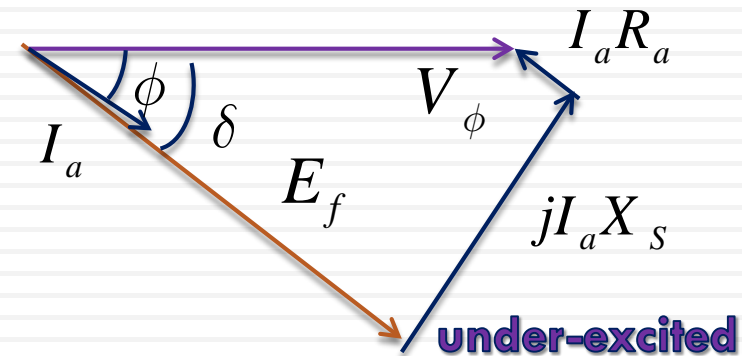

Leading Current

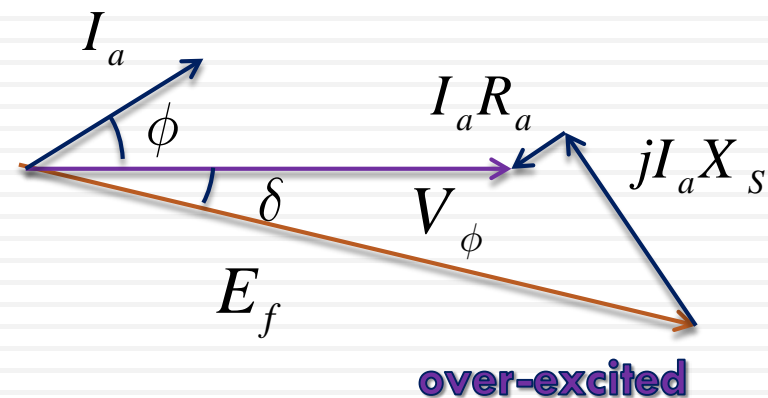

$$E_f = V_\phi - I_a [R_a + jX_s]$$

$$E_f = V_\phi - jI_a X_s \quad \text{Neglecting } R_a$$

# Synchronous Motor: Power Flow

5

## Power Flow

$$P_{in} = \sqrt{3}V_L I_L \cos \phi$$

$$P_{iron}$$

$$P_{cu} = 3I_a^2 R_a + I_f^2 R_f$$

$$P_{stray losses}$$

$$P_{mech losses}$$

$$P_{out} = T_{out} \omega_s$$

$$P_d$$

$$P_d = T_d \omega_s$$

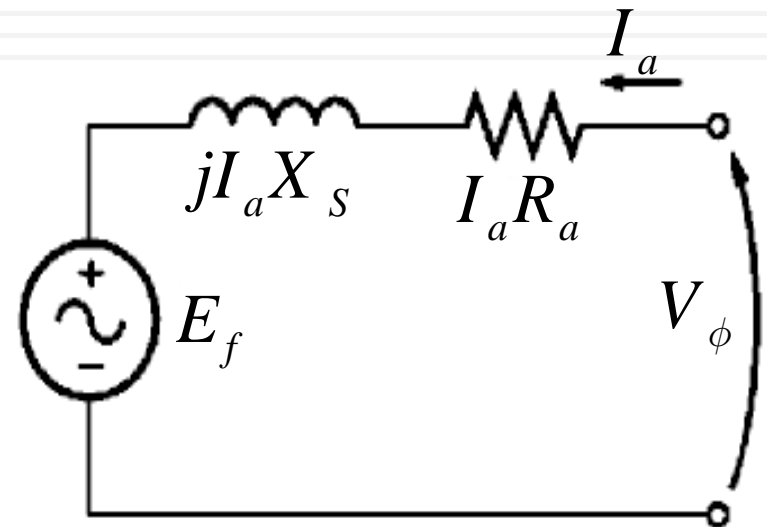
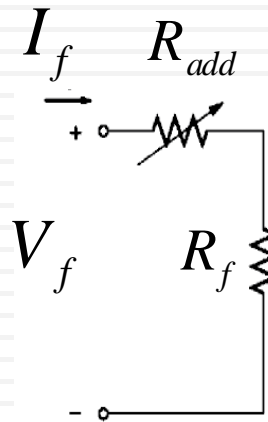

# Synchronous Motor: Torque-Speed Characteristics

6

$$P_d = \frac{3V_\phi E_f \sin \delta}{X_s}$$

$$T_d = \frac{3V_\phi E_f \sin \delta}{\omega_s X_s}$$

$\delta = \text{Torque Angle}$

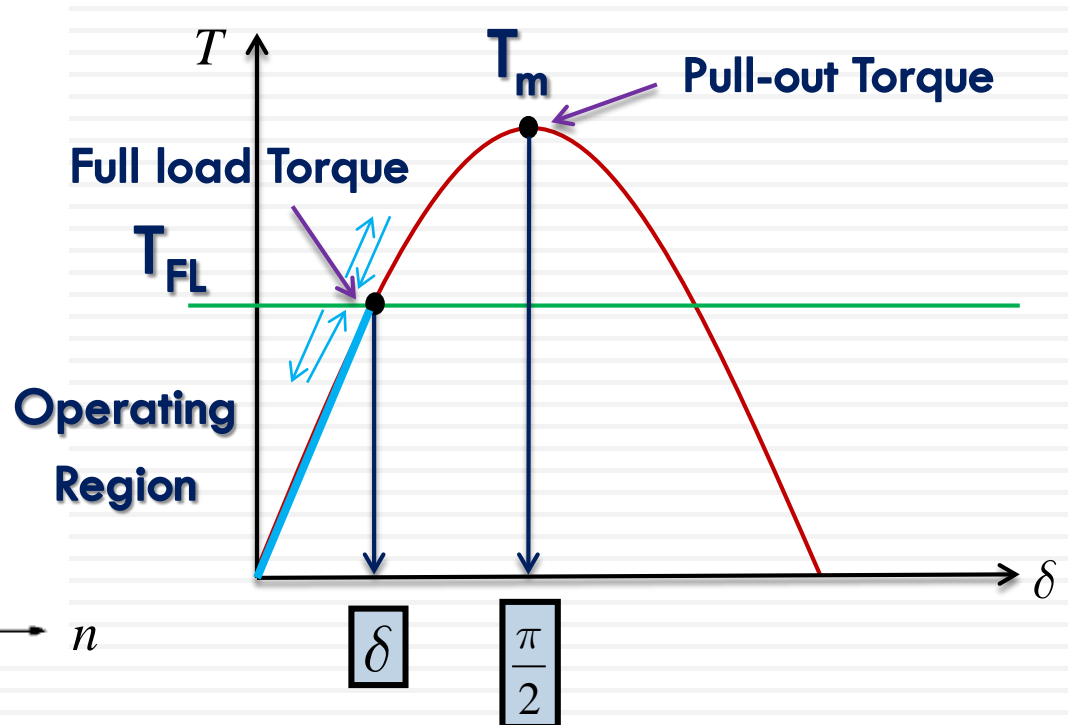
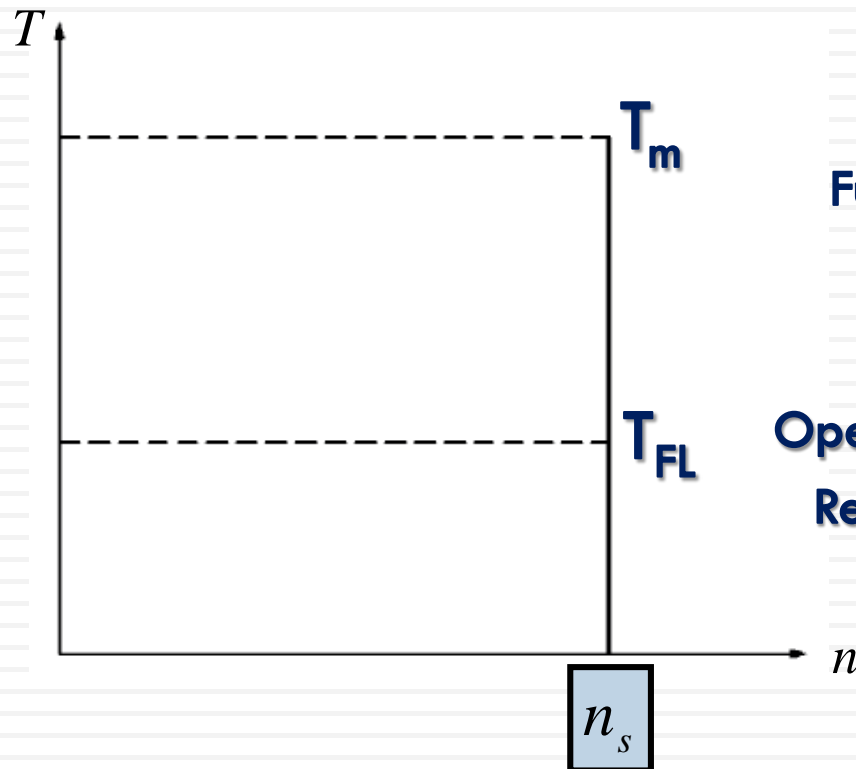

# Synchronous Motor: Modes of Operation

7

## Effect of load changes at constant field current

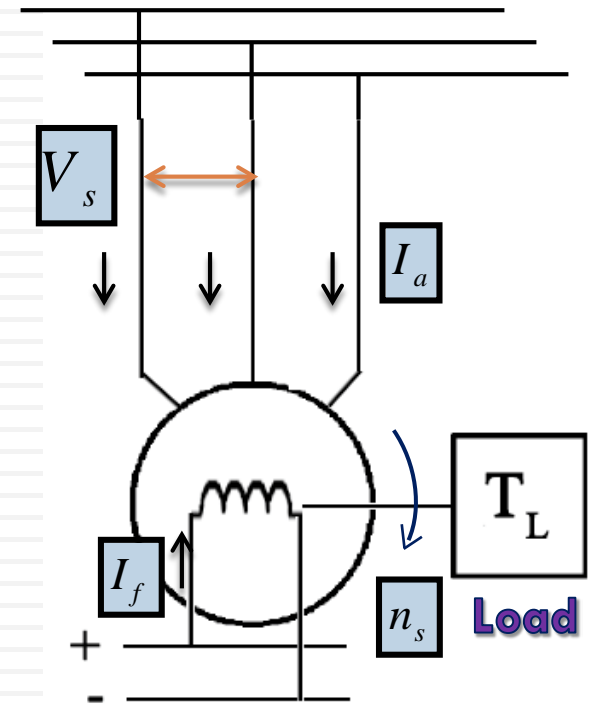
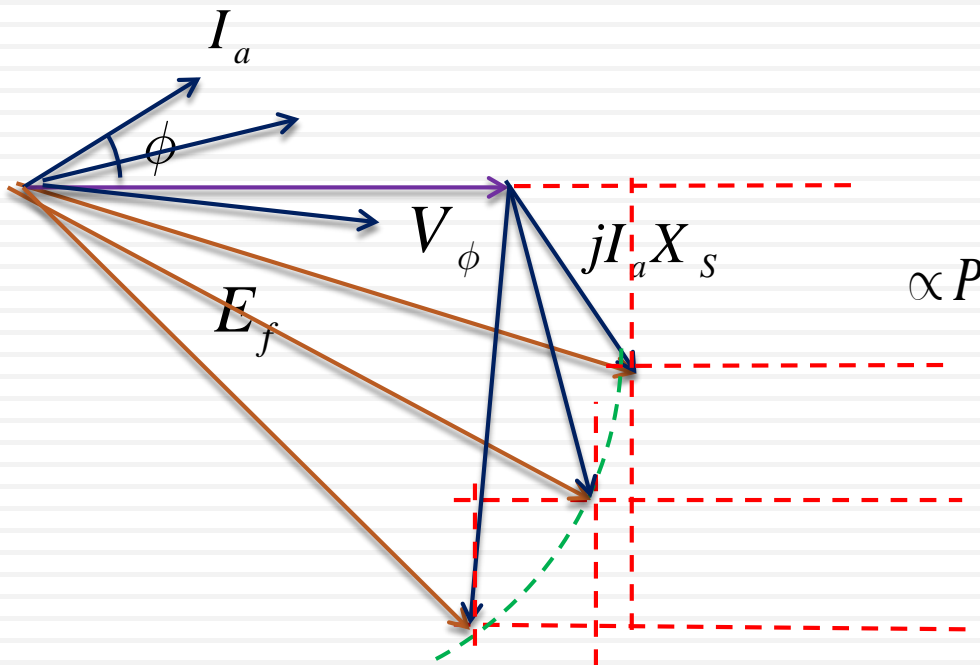
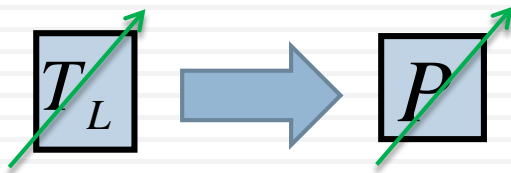

# Synchronous Motor: Modes of Operation

8

## Effect of changing field current at constant load

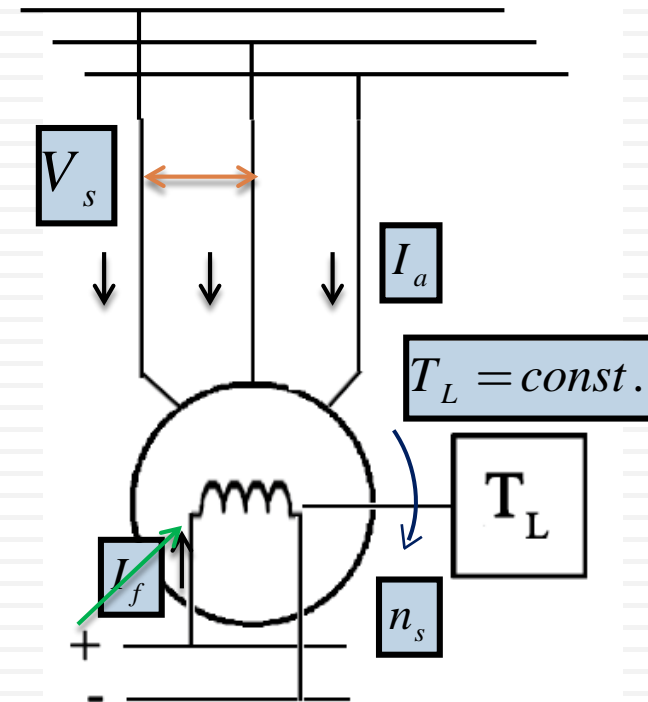
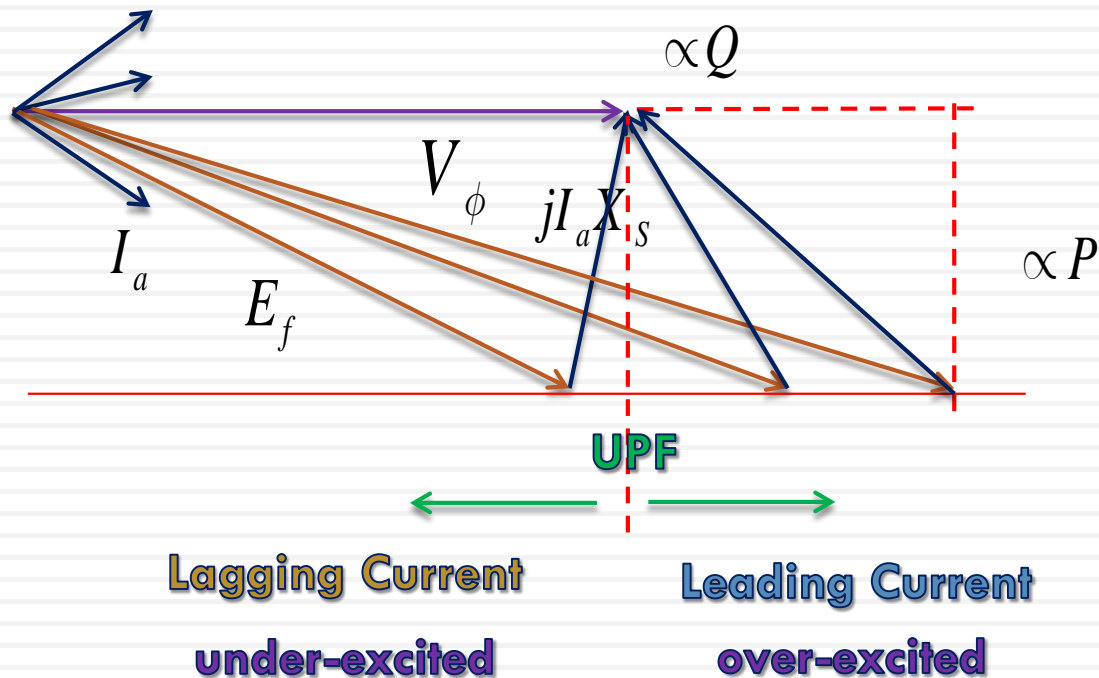
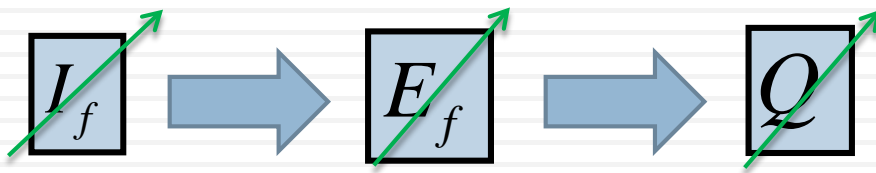

# Synchronous Motor: Modes of Operation

9

## Effect of changing field current at constant load

### V-curves

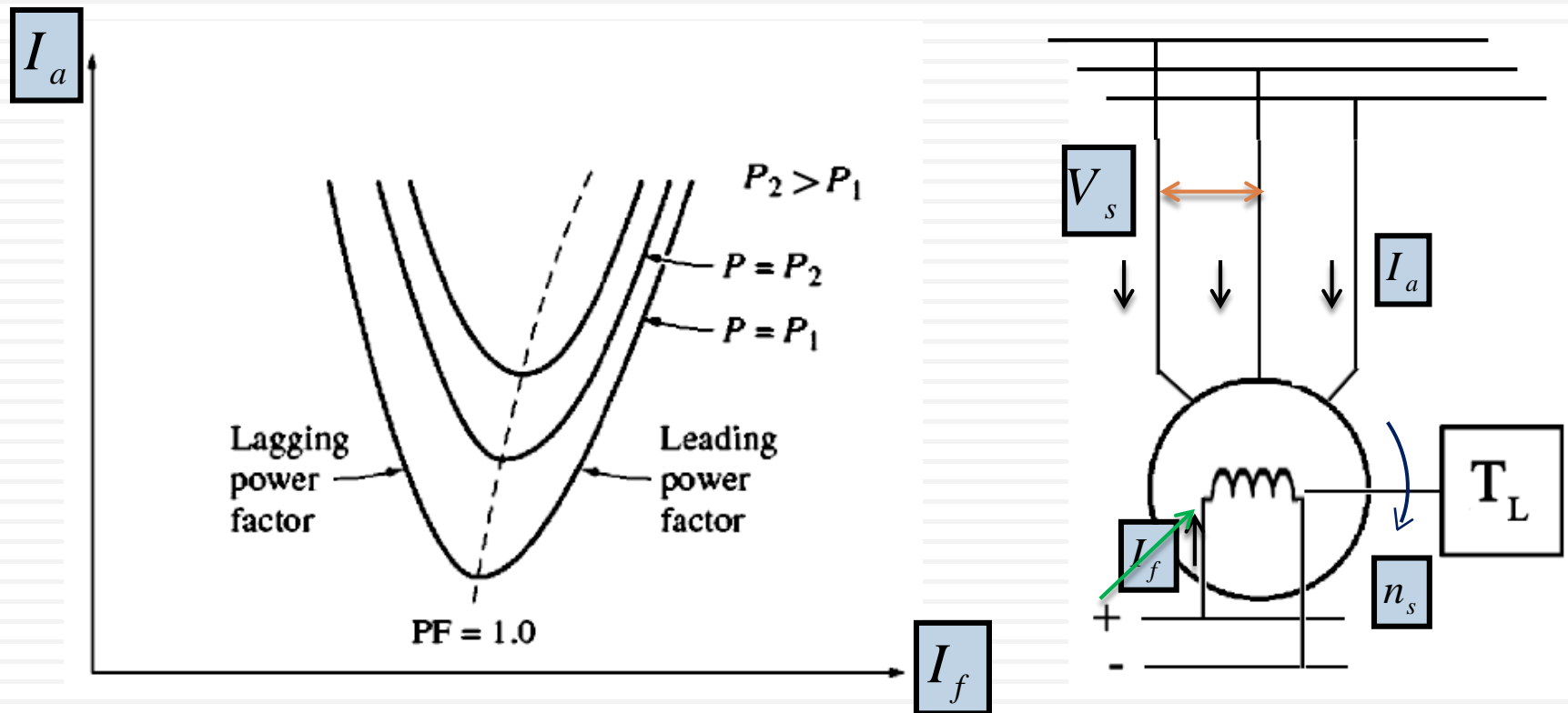

# Synchronous Motor: Modes of Operation

10

## No-load Operation (synchronous condenser/capacitor)

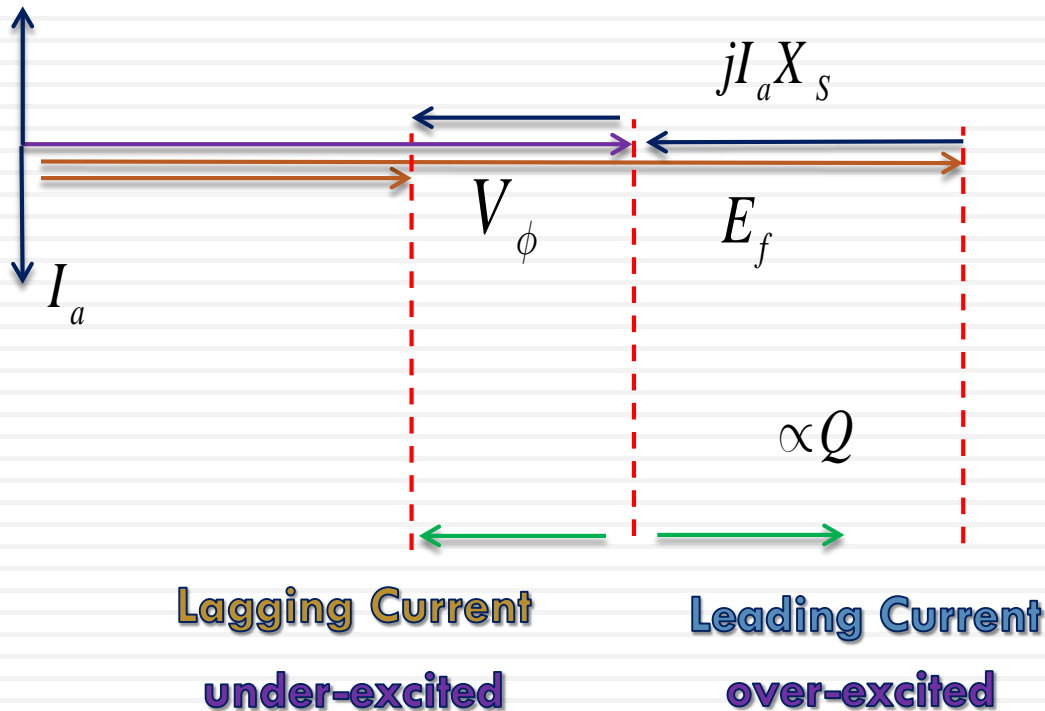
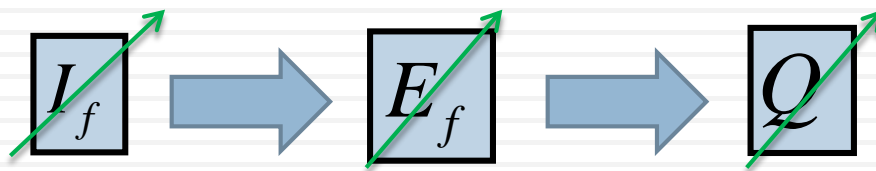

$$E_f = V_s - jI_a X_s$$

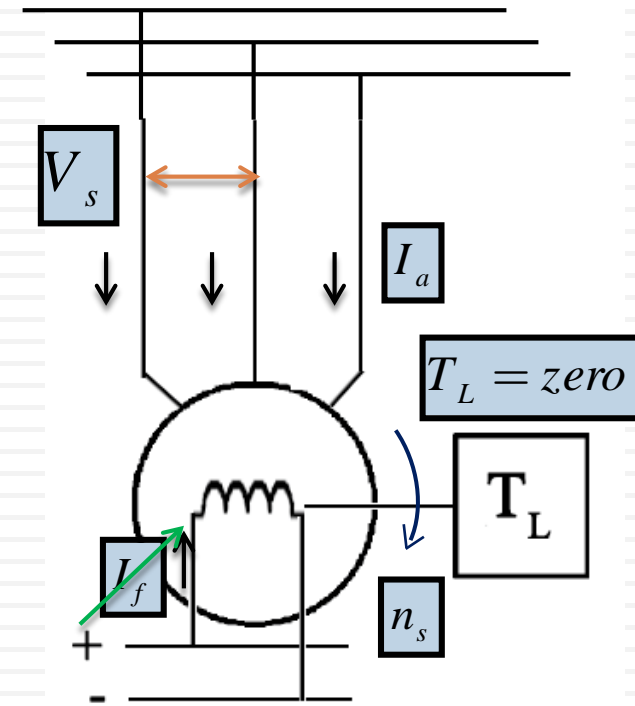

# Synchronous Motor: Modes of Operation

11

## No-load Operation (synchronous condenser/capacitor)

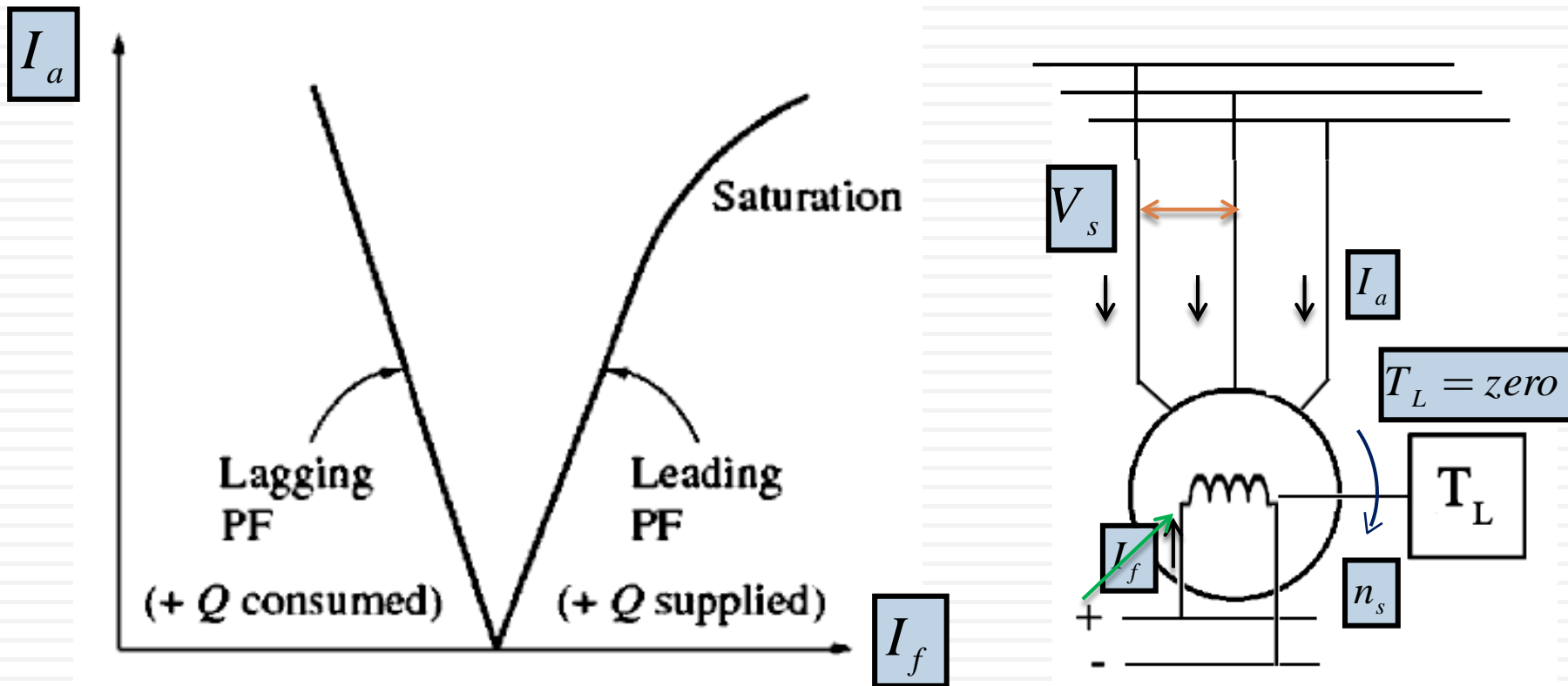

# Synchronous Motor: Starting

12

## Motor Starting Approaches

1. Increase the speed of the stator field gradually.
2. Use damper winding.
3. Use an external prime-mover.

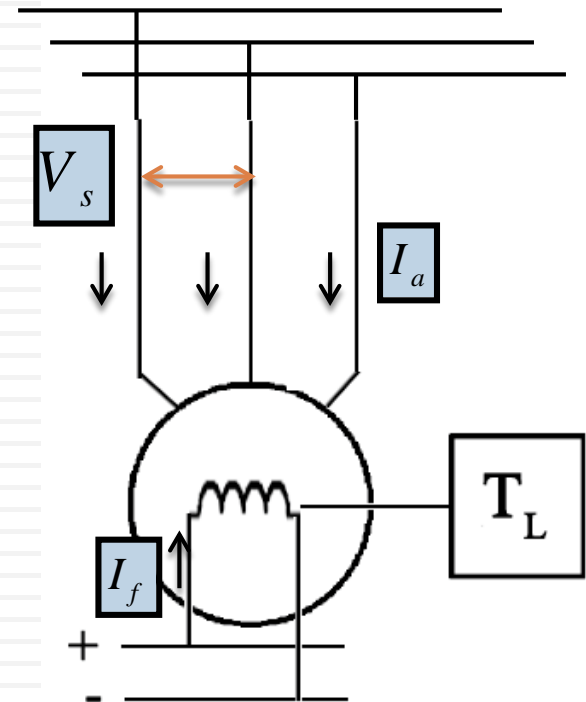

# Synchronous Motor: Starting

13

**1. Increase the speed of the stator field gradually** by gradually increasing the supply frequency from 0 to 50-60 Hz. At low enough stator field speeds, there will be enough torque for the rotor to accelerate and lock in with the stator field.

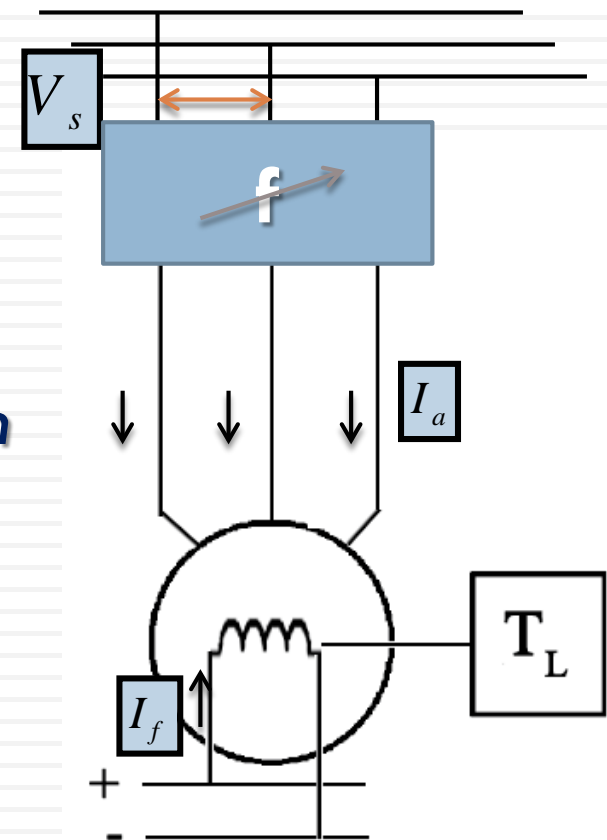

# Synchronous Motor: Starting

14

## 2. Use damper winding

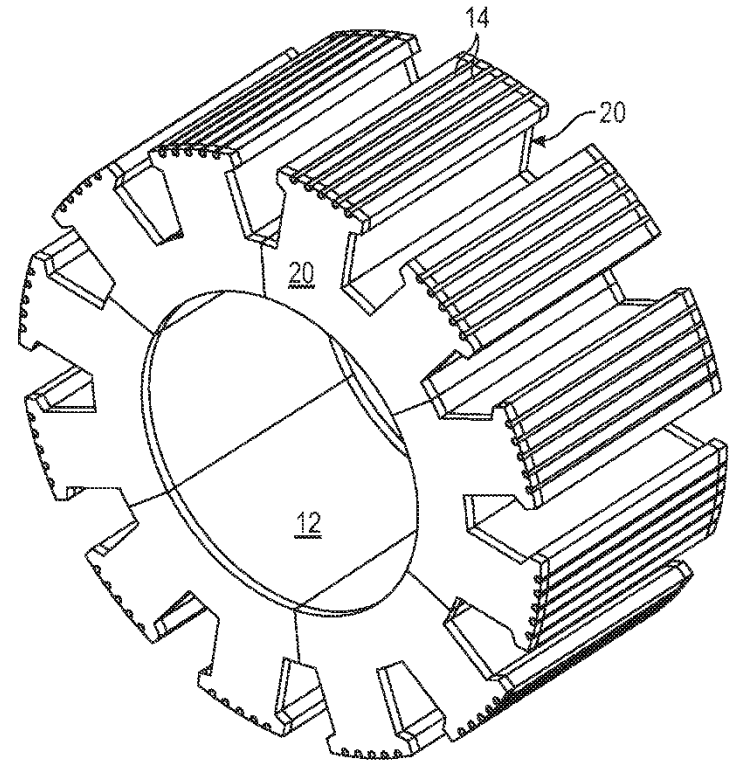
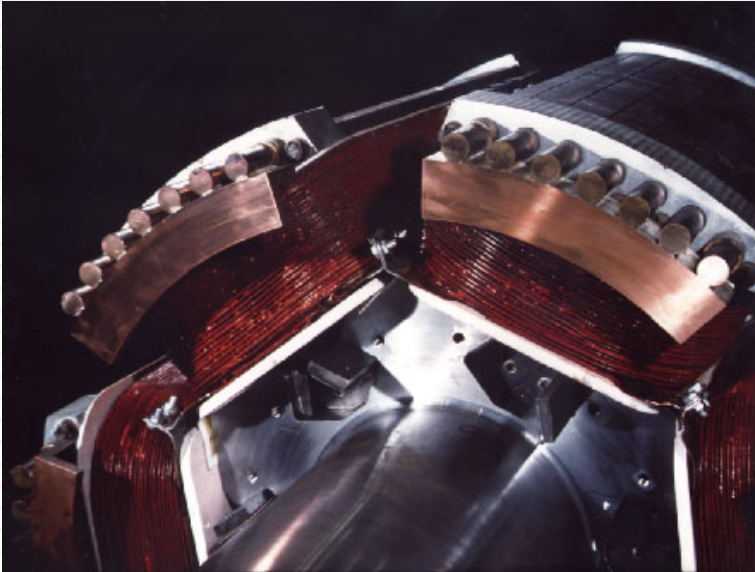

# Synchronous Motor: Starting

15

## 2. Use damper winding

*This winding allow the motor to start as an induction motor.*

*a. Disconnect the field winding and short circuit through a resistance.*

*b. Apply the supply voltage and let the rotor accelerate to near synchronous speed.*

*c. Connect the dc field supply. A pull-in torque will be developed and the rotor will rotate at synchronous speed.*

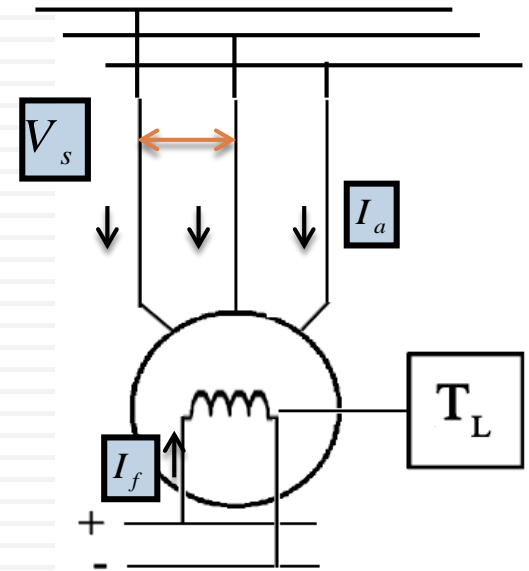

# Synchronous Motor: Starting

16

## 3. Use an external prime-mover

Using an external starting motor to bring the synchronous motor up to full speed.

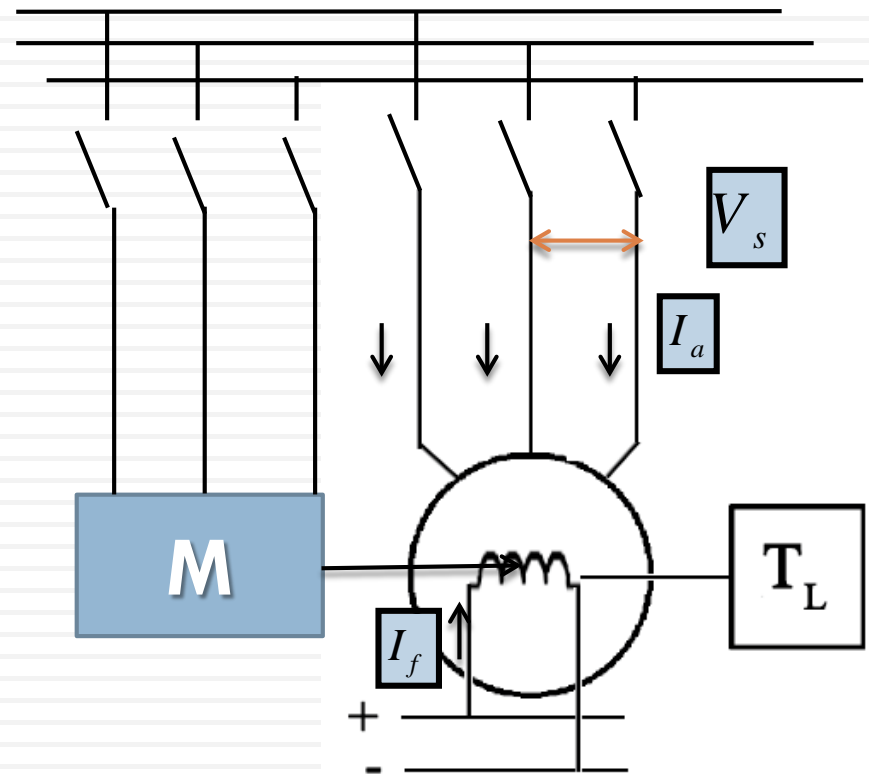

# Synchronous Motor: Applications

17

*Suitable for constant speed, continuous running loads.*

## **Advantages:**

- 1. Constant speed under load and supply voltage variations.*
- 2. High efficiency (92-96%).*
- 3. Controllable Power factor*

## **Disadvantages:**

- 1. DC current excitation.*
- 2. High initial cost (not suitable below 50 hp)*

# Synchronous Motor: Motor Rating

18

**GENERAL ELECTRIC**  
**SYNCHRONOUS MOTOR**

RATED HP	21,000	RPM	1200	PF	1.0		
VOLTS	6600	PHASE	3	FREQ	60	CODE	B
AMP	1404	FRAME	9398	TYPE	TS		
EXCITATION-VOLTS	125	AMP	5.2				
HP 21,000 CONT.	80 °C RISE	STATOR BY RTD	105 °C RISE	ROTOR BY RESISTANCE			

**OUTLINE-816E357**

<b>CAUTION</b>	BEFORE INSTALLING	INSTRUCTIONS	GEK-42586
	OR OPERATING READ	CONN. DIAG.	34A150850

WHEN ORDERING RENEWAL PARTS, GIVE THIS MOTOR MODEL & SERIAL NO.

MODEL	264766	SER. NO	8374051
-------	--------	---------	---------

MP 34A770169-001 **SCHENECTADY N. Y.** MADE IN U.S.A.

# Synchronous Motor: Motor Rating

19

## *Ratings for Toshka Pumping Station Motors*

Rated power output	12,000 kW
Rated voltage	2,950 V
Rated current	1,369 A × 2
Rated power factor	0.88 (leading)
Speed	210 – 300 min <sup>-1</sup>
Frequency	35 – 50 Hz
Number of poles	20
Protection	IP54