

## Lab Session 2 - Software

### Introduction

The schematic editor programs allow the designer to draw electronic circuit (digital, analog or mixed) schematics and to automatically generate complete SPICE circuit netlist files.

Within the next labs we will use The NI Multisim 11.0 schematic editor. There are many other editors like ORCAD CAPTURE.

### Objective

- To be familiar with Multisim schematic editor.
- Verifying of Transient response, two port and Fourier analysis circuits

### A: Transient Circuit Analysis 1

#### Steps:

1. Open NI Multisim schematic editor [start>>All Programs>>National Instrument>>Circuit Design Suite 11.0>>Multisim 11.0]. Next window will be shown:

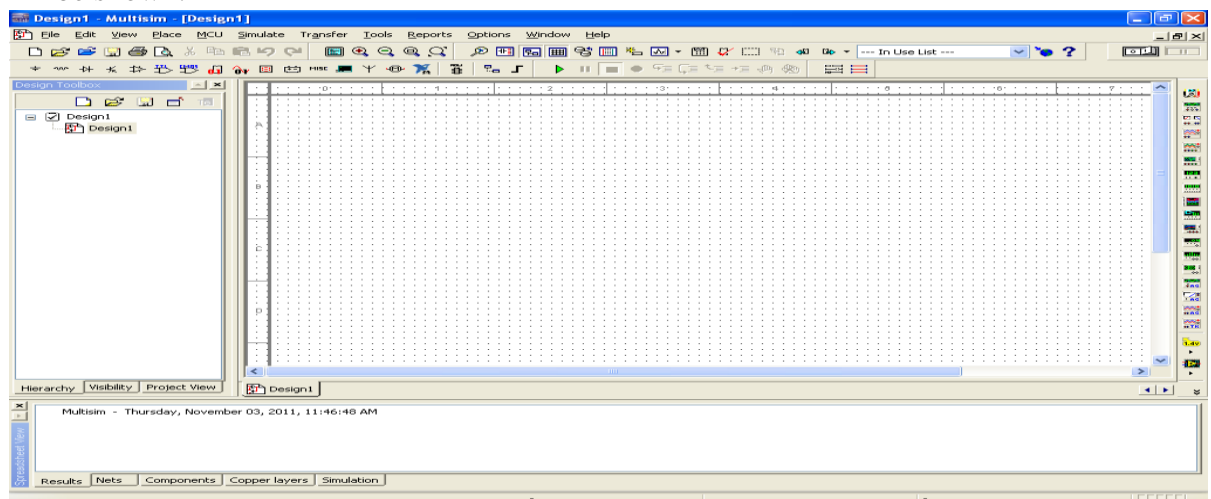

2.

Now you can observe the work sheet where you can place the circuit parts.

- From menu bar click on [Place >> Component...] then select resistor R by choosing

**Group:** "Basic", **Family:** RESISTOR, **Component:** 1k

Click OK and place the resistor in the location you want by left click. Then the window "select a Component" is appeared again.

3. Add the capacitor C by choosing **Group:** "Basic", **Family:** CAPACITOR, **Component:** 100n.
4. Add the Pulse Voltage source to schematic by choosing **Groups** : "sources", **Family:** SIGNAL\_VOLTAGES\_SOURCES, **Component:** PULSE\_VOLTAGE
5. Add the ground to schematic by choosing **Groups** : "sources", **Family:** POWER\_SOURCES, **Component:** GROUND
6. Adjust The initial voltage of PULSE\_VOLTAGE to be 0 by double click on PULSE\_VOLTAGE component.
7. Wiring the inserted components as the shown figure by the following steps :
  - a. Click on a pin on a component to start the connection (your pointer turns into a crosshair) and move the mouse. A wire appears, attached to your cursor.
  - b. Click on a pin on the second component to finish the connection. Multisim automatically places the wire, which conveniently snaps to an appropriate configuration, as shown below. This feature saves a great deal of time when wiring large circuits.

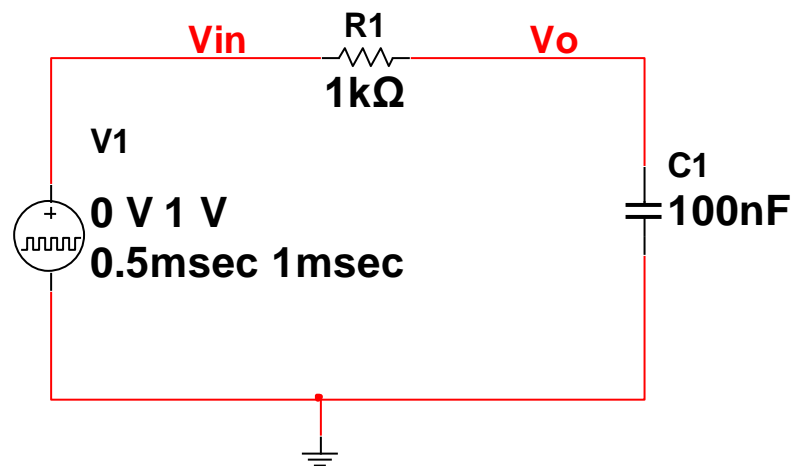

8. To label the important nodes (inputs and output)
  - Double-click on the wire that is attached to capacitor C1 and change the net name to Vo in the **Net** dialog box.
  - Double-click on the wire that is attached between V1 and R1 and change the net name to Vin in the **Net** dialog box.
9. From Kirchoff's laws, it can be shown that the charging voltage  $V_c(t)$  across the capacitor is given by:

$$V_c(t) = V_{max}(1 - e^{-t/\tau})$$

where,  $V_{max}$  is the maximum applied source voltage to the circuit for  $t \geq 0$ .  
 $\tau = RC$  is the time constant. The response curve is increasing as shown :

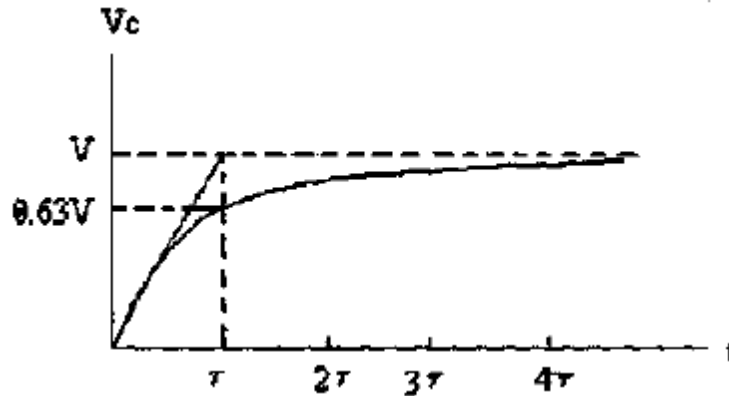

The discharge voltage for the capacitor is given by:

$$V_c(t) = V_0 e^{-t/\tau}$$

Where  $V_0$  is the initial voltage stored in capacitor at  $t = 0$ , and  $\tau = RC$  is time constant. The response curve is a decaying exponential as shown

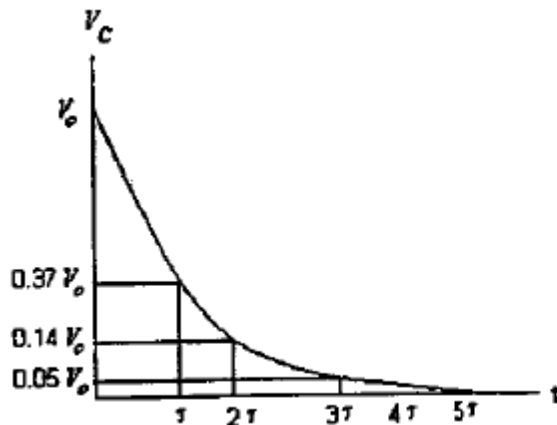

$t$	$e^{-t/\tau}$
$\tau$	0.37
$2\tau$	0.14
$3\tau$	0.05
$4\tau$	0.02
$5\tau$	0.01

10. To set up the Transient Analysis simulations (plot versus the Time):  
From menu bar click on [Simulate>>Analyses>> Transient Analysis...]  
- From Analysis parameters tab set  
    \*[Start Time (TSART)] to 0.  
    \*[End Time(TSTOP)] to 0.001.  
- From Output tab add the V(Vin) and V(Vo) by selecting them from Variables in circuits list then click Add button.
11. Then click Simulate and now from the plotting draw the output and the input on same graph (**Question 1**).
12. From the plotting find the values of the output  $V_o$  at times  $\tau$ ,  $2\tau$ ,  $3\tau$ ,  $4\tau$ ,  $5\tau$  during charging the capacitor as well as the discharging ( for discharging case, consider zero time to 0.5msec)(**Question 2**).

Hint: you should use cursors [cursor>> show cursors] 2 cursors 1 and 2 appear on the screen, select one of them and notice the X (Time) and Y(the voltage in this case) values corresponding to the selecting cursor.

## **B: Transient Circuit Analysis 2**

To simulate the shown figure

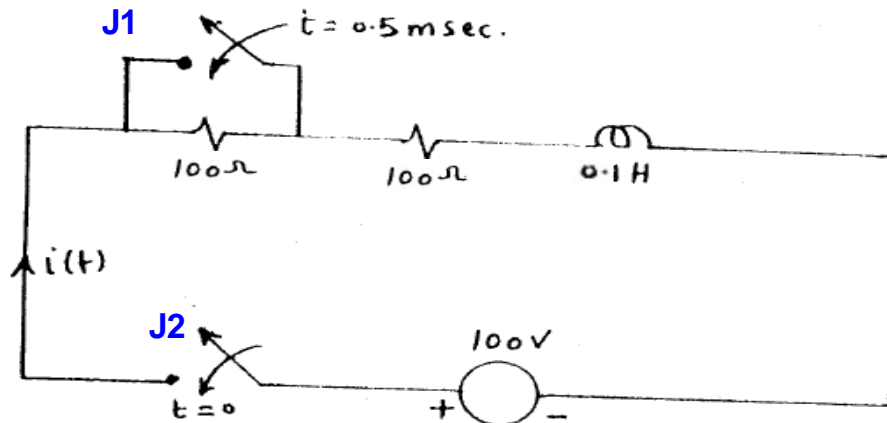

1. Open new schematic by clicking [file>>New >>Design].
2. Add the following components from menu bar click on [Place >> Component...]
  - Add two resistors 10 ohm and an inductor 1H to schematic.
  - Add two SWITCHES to schematic by choosing  
**Groups** : "BASIC", **Family**: SWITCH, **Component**: TD\_SW1\_\_\_\_\_
  - Add the DC Voltage source to schematic by choosing  
**Groups** : "sources", **Family**: POWER\_SOURCES, **Component**: DC\_POWER.
  - Add the ground to schematic by choosing  
**Groups** : "sources", **Family**: POWER\_SOURCES, **Component**: GROUND.
3. To adjust Switches time for switch J1, double click on the switch J1 and put
  - Time on TON to 0.5m sec
  - Time Off TOFF to 100 sec.
4. To adjust Switches time for switch J2, double click on the switch J2 and put
  - Time on TON to 1n sec
  - Time Off TOFF to 100 sec.
5. Connect the circuit as shown figure.
6. Draw the current through L1 I(L1) versus time (**Question 3**)  
[Hint: use Transient Analysis and adjust TSART to 0 and TSTOP to 0.004].

### C: Transient Circuit Analysis 3

To simulate the shown figure

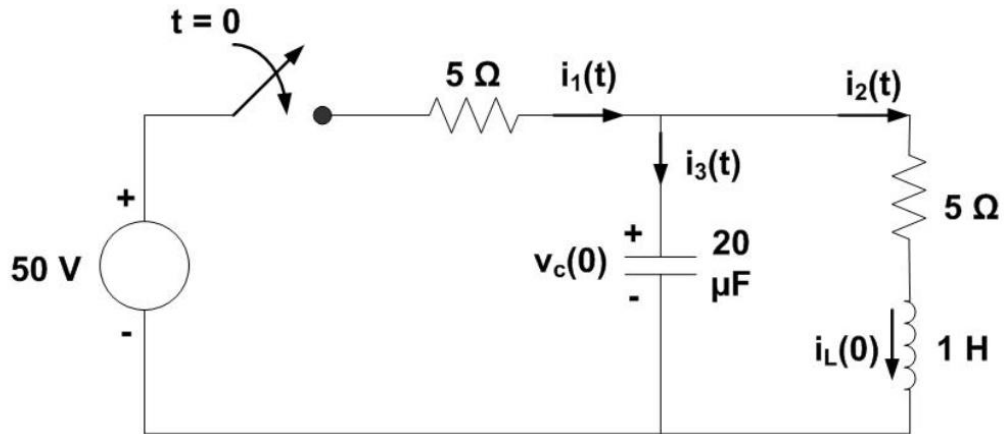

1. Open new schematic by clicking [file>>New >>Design].
2. Draw the circuit on Multisim and the value of components as required.
3. The initial condition on the capacitor and inductor are  $v_c(0) = 20V$  and  $i_L(0) = 2A$  respectively.
4. To initialize the capacitor and coil double click on each one and check on Initial Conditions box and put the initial value.
5. Draw the currents  $i_1(t)$ ,  $i_2(t)$ ,  $i_3(t)$  (**Question 4**).

Note: To set up the Transient Analysis simulations

From menu bar click on [Simulate>>Analyses>> Transient Analysis...]

From Analysis parameters tab set

\*[Start Time (TSART)] to 0.

\*[End Time (TSTOP)] to 1.

The circuit schematic would look like this:

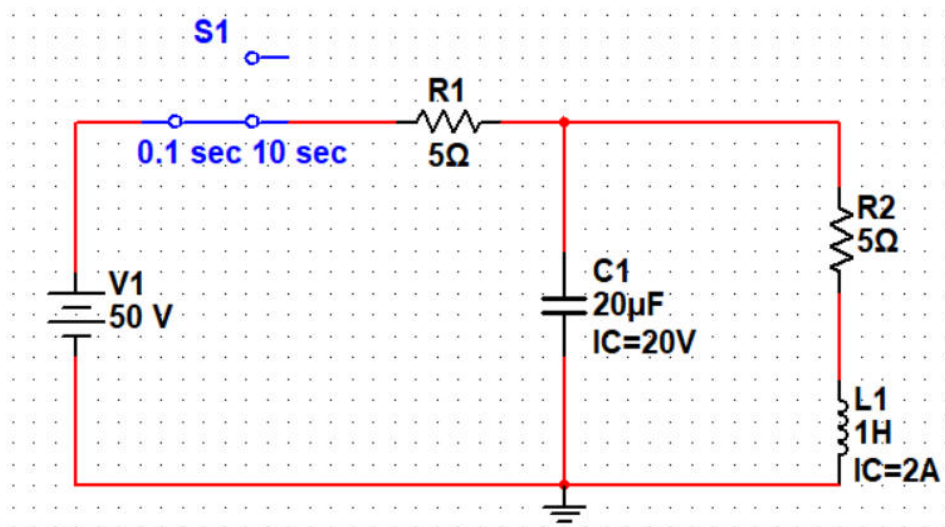

## D: Fourier Series Analysis

1. Open new schematic by clicking [file>>New >>Design].
2. Connect the shown circuit
3. From menu bar click on [Simulate>>Analyses>> AC Sweep...]
4. Find Fourier series for  $V_s$  , single Harmonic sine wave, (**Question 5**). Use [Simulate>>Analyses>> Fourier Analysis...] then click simulate.

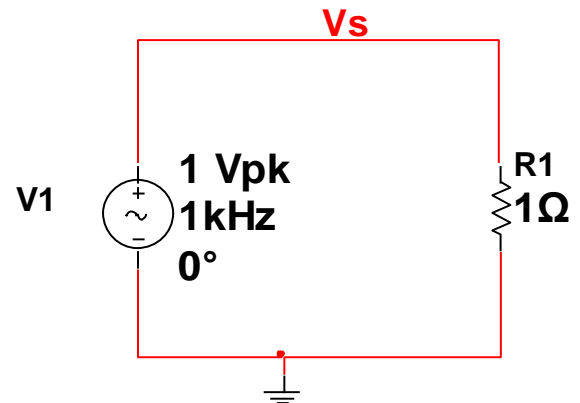

5. Connect the shown circuit
6. Add Square source to schematic by choosing  
**Groups** : "Sources",  
**Family**: SIGNAL\_VOLTAGE\_SOURCES,  
**Component**: PULSE\_VOLTAGE
7. Draw the signal  $V_s$  versus time [hint: use Transient Analysis and put TStop to 0.003] (**Question 6**).
8. Find Fourier series for  $V_s$  , single Harmonic sine wave, (**Question 7**). Use [Simulate>>Analyses>> Fourier Analysis...] then click simulate.
8. Make the clock source voltage levels to be 0 and 2V by :  
 - double click on the source V1 and adjust

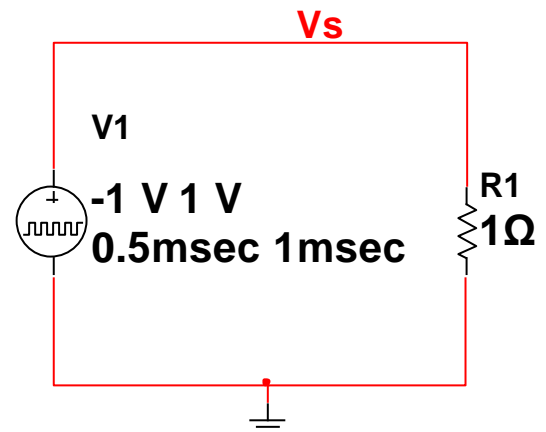

Initial Value: 0 V  
Pulsed Value: 2 V

What is the DC value in this case (**Question 8**).

9. For Triangular wave generator  
 - double click on the source V1 and adjust  
 Initial Value: -5 V  
 Pulsed Value: 5 V  
 Delay time: 0  
 Rise Time: 0.5 msec  
 Fall Time: 0.5 msec  
 Pulse width: 0  
 Period: 1 msec

**10.** Draw the signal  $V_s$  versus time [hint use Transient Analysis and put TStop to 0.003] (**Question 9** ).

11. Find Fourier series for  $V_s$  , single Harmonic sine wave, (**Question 10**). Use [Simulate>>Analyses>> Fourier Analysis...] then click simulate.



Name:

Code:

## Lab Session 2 – Software Answer Sheet

**Question 1 (Draw  $V_{in}$  and  $V_o$  versus Time )**



**Question 2**

Time	$V_c(t) = V_o(t)$ during charging	$V_c(t) = V_o(t)$ during discharging
$\tau$		
$2\tau$		
$3\tau$		
$4\tau$		
$5\tau$		

**Question 3 (Draw  $I_L$  versus Time )**





**Question 4 (Draw  $i_1(t)$ ,  $i_2(t)$ ,  $i_3(t)$  versus Time )**

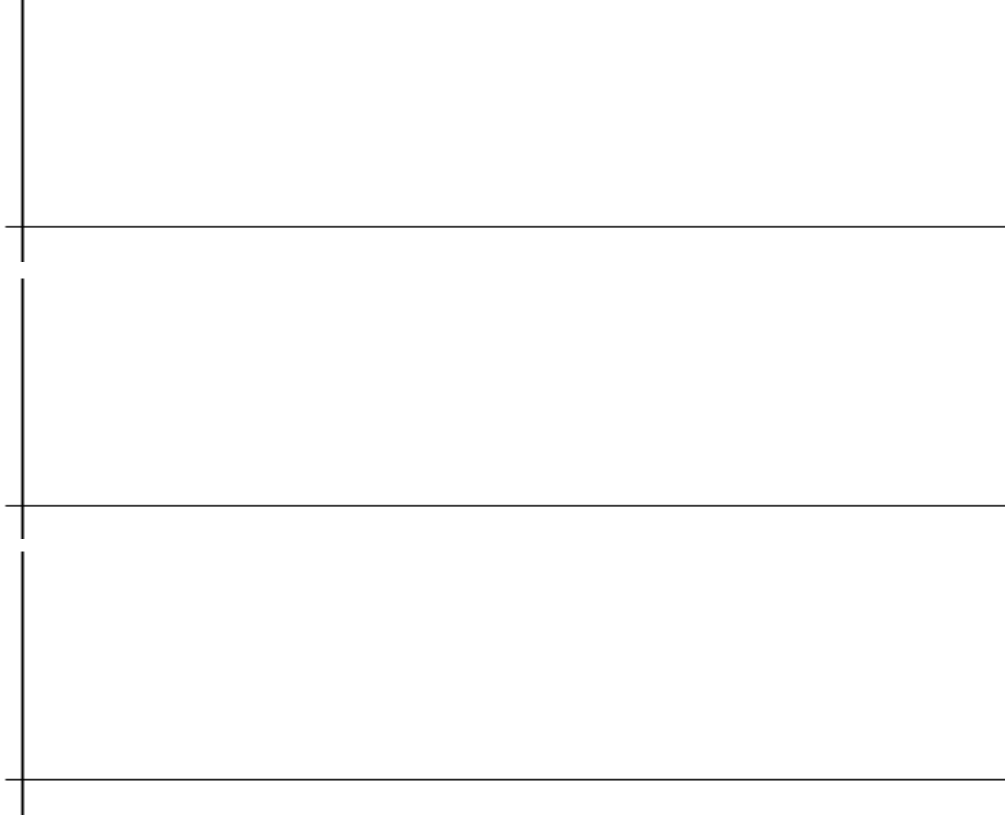



**Question 5 (Find Fourier series for  $V_s$ , sine wave)**

Harmonic	Magnitude	Phase
$DC$		
$f_0$		
$2f_0$		

**Question 6 (Draw  $V_s$  versus time)**

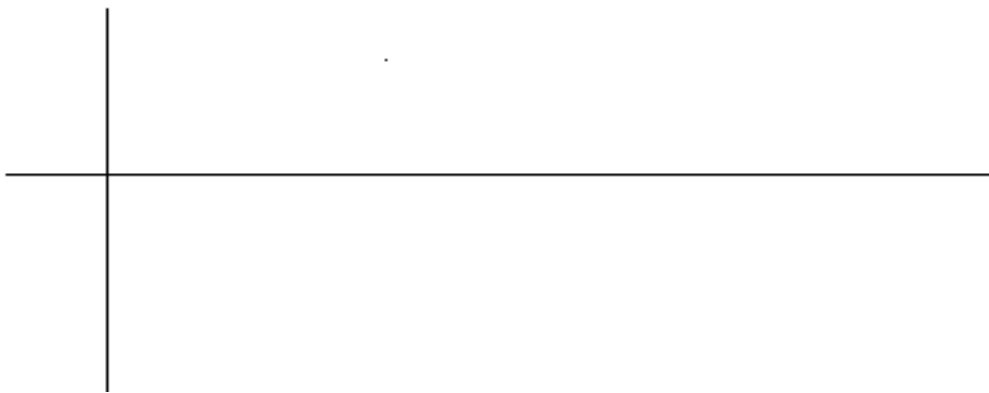

**Question 7 (Find Fourier series for  $V_s$ , Square Wave)**

Harmonic	Magnitude	Phase
$DC$		
$f_0$		
$2f_0$		
$3f_0$		
$4f_0$		
$5f_0$		

**Question 8**

DC component is: V



**Question 9 ( Draw Vs versus time)**

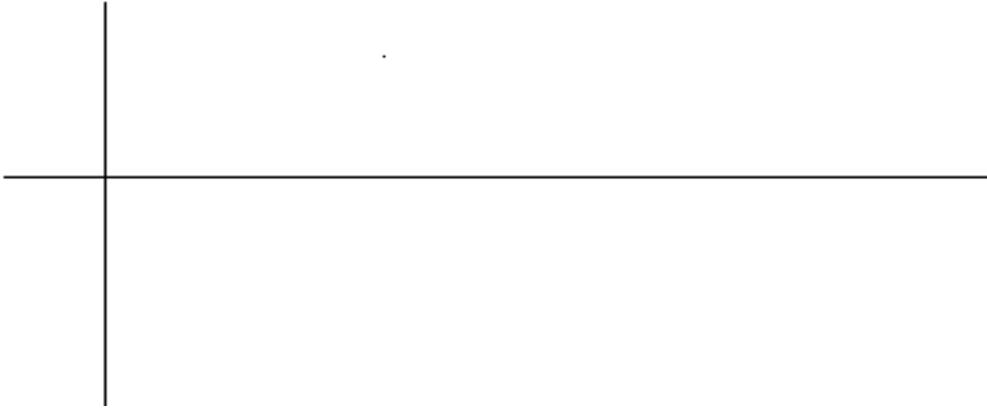

**Question 10 (Find Fourier series for Vs, Triangular Wave )**

Harmonic	Magnitude	Phase
$DC$		
$f_0$		
$2f_0$		
$3f_0$		
$4f_0$		
$5f_0$		