

Lab Session 1 - Software

Introduction

The schematic editor programs allow the designer to draw electronic circuit (digital, analog or mixed) schematics and to automatically generate complete SPICE circuit netlist files.

Within the next labs we will use The NI Multisim 11.0 schematic editor. There are many other editors like ORCAD CAPTURE.

Objective

- To be familiar with Multisim schematic editor.
- Verifying of AC analysis for resonance and filter circuits.

A: Series Resonance

Procedure:

1. Open NI Multisim schematic editor [start>>All Programs>>National Instrument>>Circuit Design Suite 11.0>>Multisim 11.0]. The window in Fig. 1 will appear.

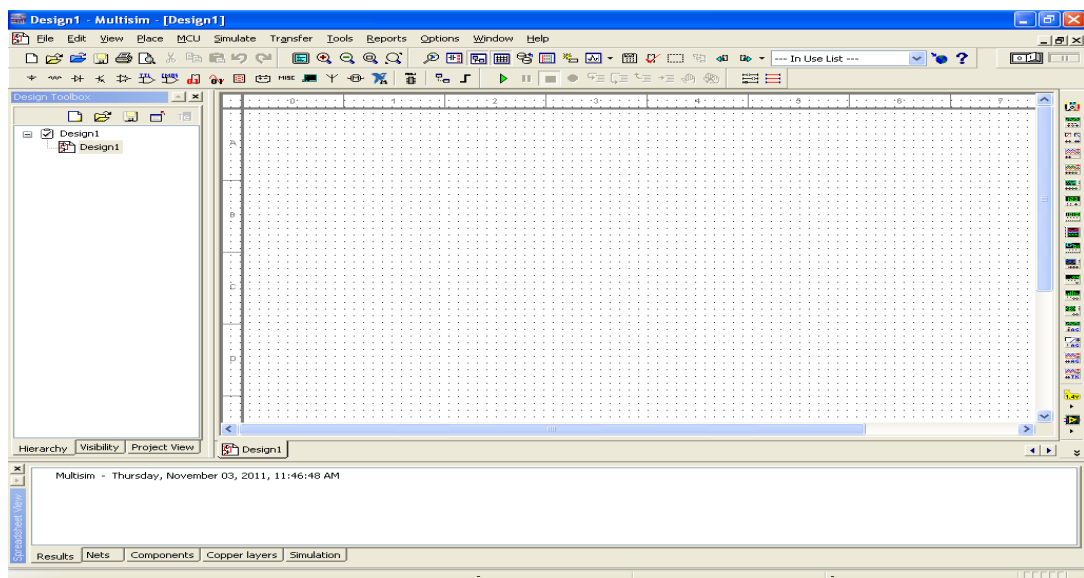

Figure 1

Now you can observe the work sheet where you can place the circuit parts. From menu bar click on [Place >> Component...] then select resistor R by choosing **Group:** "Basic", **Family:** RESISTOR, **Component:** 50 as shown in Fig. 2. Click OK and place the resistor in the location you want by left click.

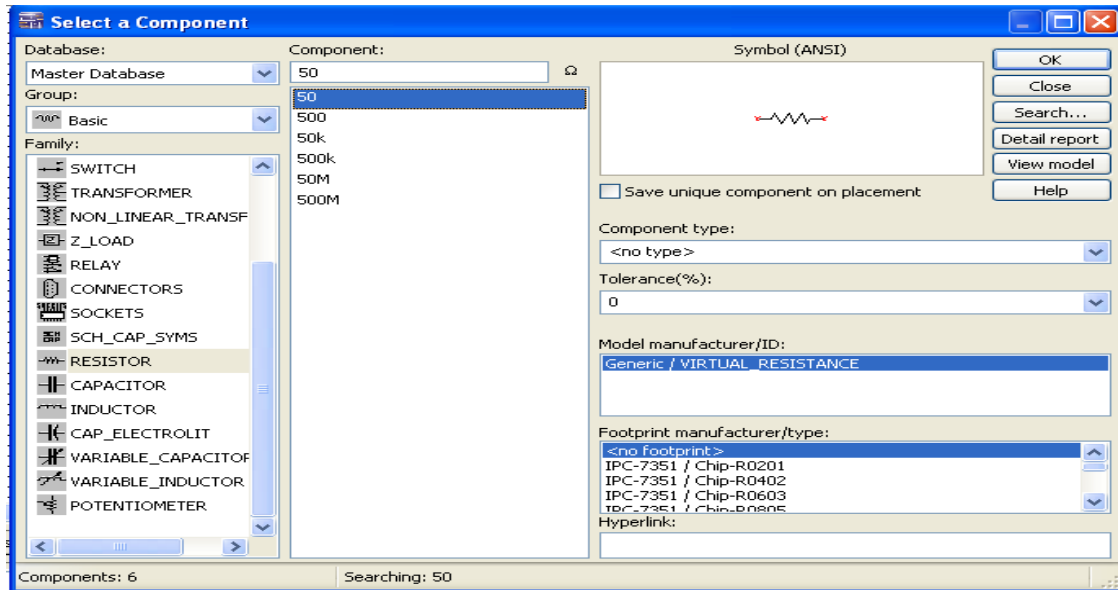

Figure 2

Then the window "select a Component" appears again.

2. Add another resistor as the last step with value 150 ohm.
 3. Add the capacitor C by choosing **Group: "Basic", Family: CAPACITOR, Component: 30n.**
 4. Add the coil L by choosing **Group: "Basic", Family: INDUCTOR, Component: 50m.**
- Add the AC power source to schematic by choosing **Groups: "sources", Family: POWER_SOURCES, Component: AC_POWER** as shown in Fig. 3.

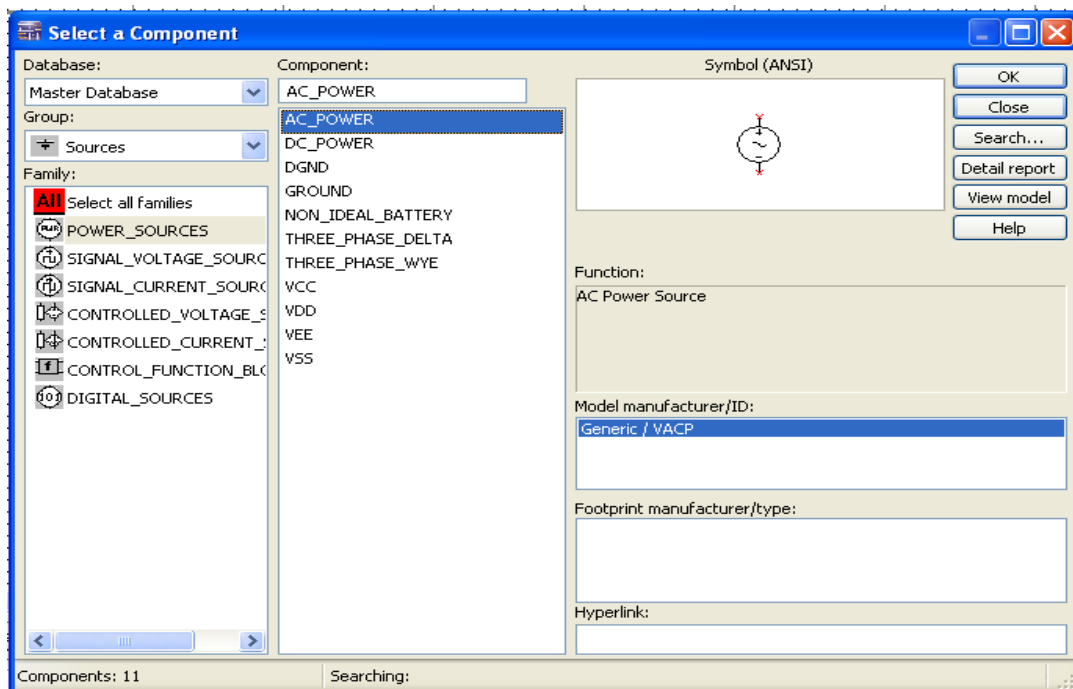

Figure 3

5. Add the ground to schematic by choosing **Groups** : "sources", **Family**: POWER_SOURCES, **Component**: GROUND
6. Wire the inserted components as the shown figure by the following steps :
 - a. Click on a pin on a component to start the connection (your pointer turns into a crosshair) and move the mouse. A wire appears, attached to your cursor.
 - b. Click on a pin on the second component to finish the connection. Multisim automatically places the wire, which conveniently snaps to an appropriate configuration, as shown below. This feature saves a great deal of time when wiring large circuits.

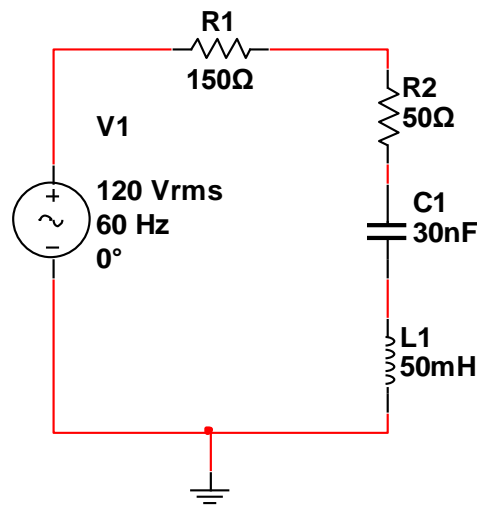

Figure 4

7. To set up the AC Sweep simulations (plot versus the frequency): From menu bar click on [Simulate>>Analyses>> AC Sweep...]
 - From Analysis parameters tab set
 - [Start Frequency (FSART)] to 100 Hz.
 - [Stop Frequency (FSTOP)] to 20 KHz.
 - [Number of points per Decade] to 1000
 - From Output tab add the I(R1) by selecting I(R1), the current which through the resistance R1, from Variables in circuits list then click Add button as shown in Fig. 5.
8. Click Simulate and now from the plotting draw the magnitude and the phase of the current I(R1) (**Question 1**).
9. From the plot, find the resonance frequency f_s and the cutoff frequencies f_1 , f_2 (**Question 2**).
Hint: you should use cursors [cursor>> show cursors] 2 cursors 1 and 2 appear on the screen, select one of them and notice the X (frequency) and Y (the current in the case) values corresponding to the selecting cursor.

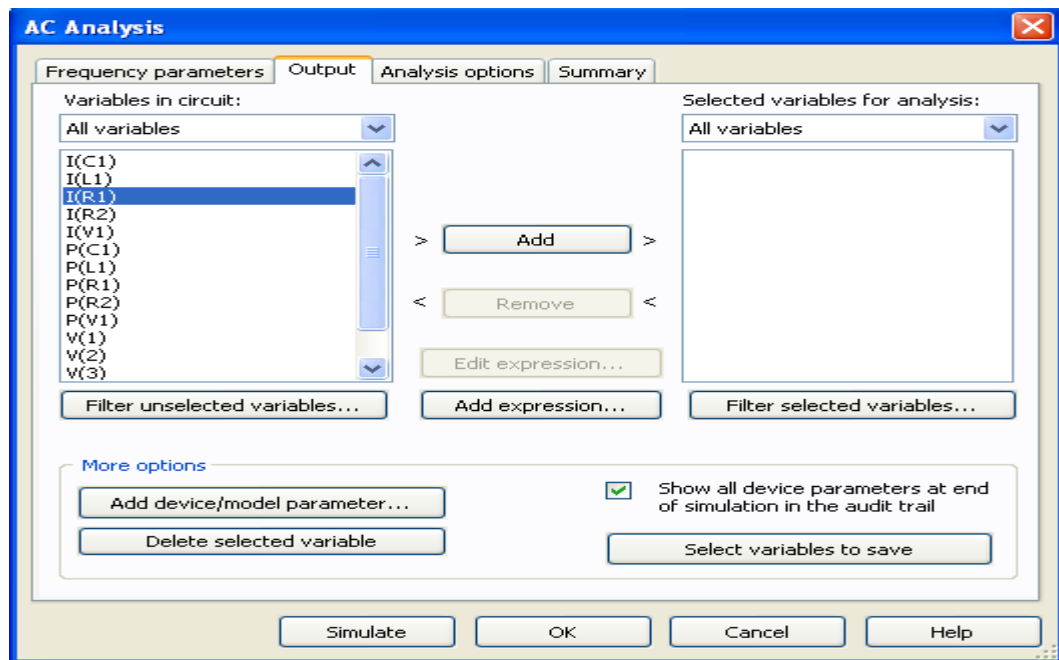

Figure 5

10. To label the important nodes (inputs and output)
 - Double-click on the wire that is attached to capacitor C1 and change the net name to C in the **Net** dialog box.
 - Double-click on the wire that is attached to the inductor L1 o and change the net name to L in the **Net** dialog box.
11. Find the voltage across the coil and the capacitor (magnitude and phase) at resonance and at a frequency 10% below the resonance (**Question 3**).
 - To plot the voltage across C1 and L1 follow the following steps:
 - From menu bar click on [Simulate>>Analyses>> AC Sweep...]
 - From Output tab add the voltage across L1 V(l)
 - Click "Add Expression..." and insert "V(c)-V(l) ", which is the voltage across the capacitor C1, in expression field then click OK.
12. Click Simulate and now from the plot answer Question 3. Use cursor
13. Find the power dissipated in the circuit at resonance (**Question 4**).
Hint: draw P(V1) power delivered by the source V1

B: Parallel Resonance

1. Open new schematic by clicking [file>>New >>Design].
2. Add the following components from menu bar click on [Place >> Component...]
 - Add resistor 20 ohm, 5K ohm, capacitor 0.24 μ F and inductor 25mH to schematic.

- Add the AC current source to schematic by choosing **Groups:** "sources", **Family:** SIGNAL_CURRENT_SOURCES, **Component:** AC_CURRENT.
 - Add the ground to schematic by choosing **Groups:** "sources", **Family:** POWER_SOURCES, **Component:** GROUND.
3. Connect the circuit as shown figure.

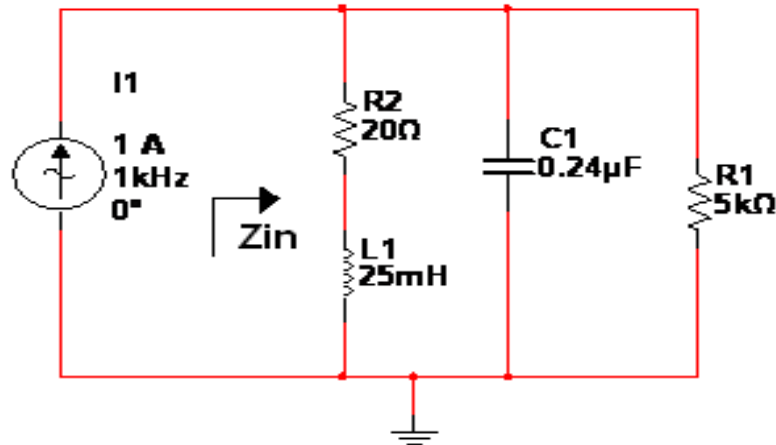

Figure 6

4. Double-click on the wire that is attached to capacitor C1 and change the net name to p in the **Net** dialog box.
5. To set up the AC Sweep simulations (plot versus the frequency):
From menu bar click on [Simulate>>Analyses>> AC Sweep...]
 - From Analysis parameters tab set
 - [Start Frequency (FSART)] to 100 Hz.
 - [Stop Frequency (FSTOP)] to 20 KHz.
 - [Number of points per Decade] to 1000.
 - From Output tab click "Add Expression..." and insert " V(p)/I(I1)", which is input impedance Z_{in} , in expression field then click OK.
6. Click Simulate and now from the plotting draw the magnitude and the phase of the Z_{in} (**Question 5**).
7. Find the range of frequencies between f_a and f_b for which $|Z_{in}| \geq 1.5K\Omega$ (**Question 6**).

C: Double tuned filter

1. Open new schematic by clicking [file>>New >>Design].
2. Connect the circuit as shown figure.

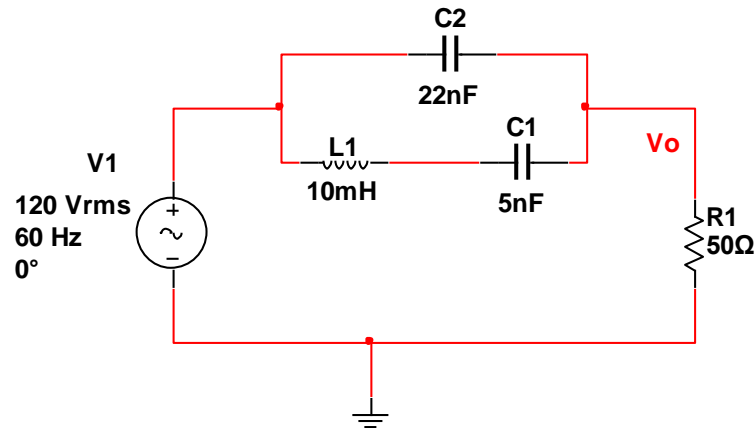

Figure 7

3. Find the rejected and accepted signal frequencies and sketch the response of the filter output (**Question 7**). [Hint: Set up the AC Sweep simulations and plot the output Vo]

D: Electric Filters 1

1. Open new schematic by clicking [file>>New >>Design].
2. Connect the circuit as shown figure.

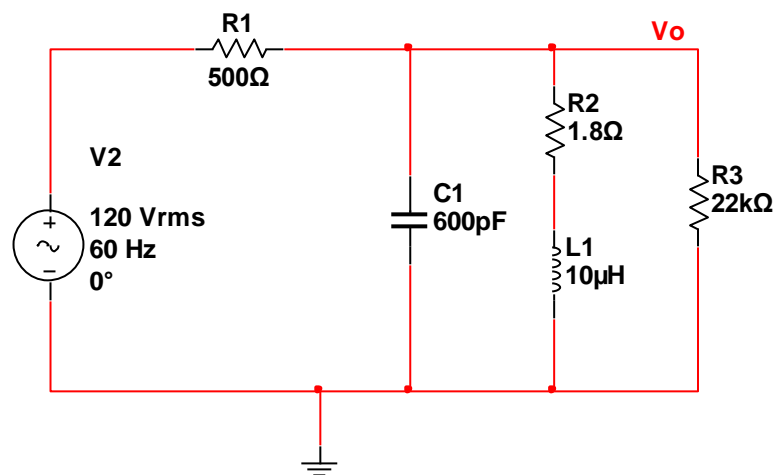

Figure 8

3. Identify the type of filter, plot the response of the filter, find the resonance frequency, the cutoff frequencies f_1 , f_2 and bandwidth (**Question 8**). [Hint: Set up the AC Sweep simulations and plot the output Vo].

E: Electric Filters 2

1. Open new schematic by clicking [file>>>New >>Design].
2. Connect the circuit as shown figure.

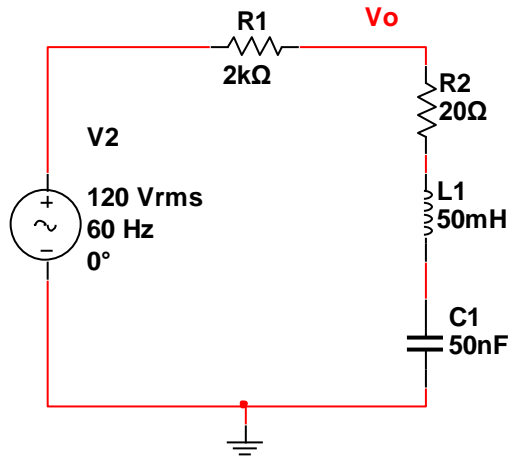

Figure 9

3. Identify the type of filter, plot the response of the filter, find the resonance frequency, the cutoff frequencies f_1 , f_2 and bandwidth (**Question 9**). [Hint: Set up the AC Sweep simulations and plot the output Vo].



Name (In Arabic):

Code:

Lab Session 1 – Software – Answer Sheet

Question 1 (Draw magnitude of $I(R1)$ versus frequency)



(Draw Phase of $I(R1)$ versus frequency)



Question 2 (Find the resonance frequency f_s and the cutoff frequencies f_1, f_2)

$$f_s =$$

$$f_1 =$$

$$f_2 =$$

Question 3 (Find the voltage across the coil and the capacitor (magnitude and phase) at resonance and at a frequency 10% below the resonance)

$$V_l \text{ at } f_s =$$

$$V_c \text{ at } f_s =$$

$$V_l \text{ at } 10\% \text{ below the resonance} =$$

$$V_c \text{ at } 10\% \text{ below the resonance} =$$

Question 4 (Find the power dissipated in the circuit at resonance)

$$P_{disp} \text{ at } f_s =$$



Question 5 (Draw magnitude of Z_{in} versus frequency)



(Draw Phase of Z_{in} versus frequency)



Question 6 (Find the range of frequencies between f_a and f_b for which $|Z_{in}| \geq 1.5K\Omega$).

$$f_a =$$

$$f_b =$$

The range is:

Question 7 (Find the rejected and accepted signal frequencies and sketch the response of the filter output)

$$f_{\text{accepted}} =$$

$$f_{\text{rejected}} =$$



Question 8 (Identify the type of filter, plot the response of the filter, find the resonance frequency, the cutoff frequencies f_1 , f_2 and Bandwidth

(Draw magnitude of V_o versus frequency)

The type of filter is:

The resonance frequency is:

$$f_1 =$$

$$f_2 =$$

Bandwidth is:



Question 9 (Identify the type of filter, plot the response of the filter, find the resonance frequency, the cutoff frequencies f_1 , f_2 and Bandwidth

The type of filter is:

The resonance frequency is:

$$f_1 =$$

$$f_2 =$$

Bandwidth is:



Cairo University
Faculty of Engineering
Giza Campus

Department of Communications
and Computer Engineering
ELCN112



(Draw magnitude of V_o versus frequency)

