

## Foliation and lineation

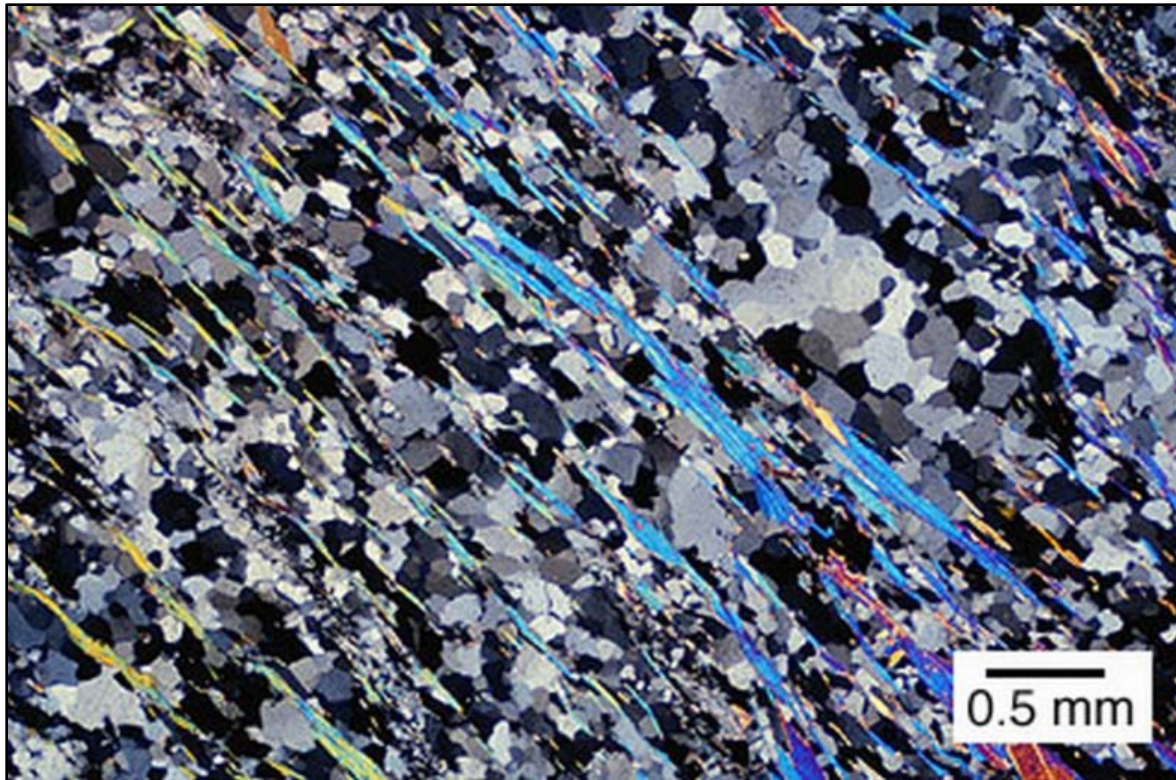

## Regional metamorphism

Caused by the effect of pressure and temperature on a regional scale, resulting in the recrystallization and preferred orientation of constituent minerals forming foliation (schistosity and gneissosity). This process is a ductile deformation and usually associated with the development of new metamorphic minerals such as biotite, garnet, sillimanite, staurolite. Deformation is marked by the elongation and preferred orientation of minerals.





**Foliation in metamorphic rocks**



Foliation in metamorphic rocks

# Foliation (Rock cleavage)

Foliation is a planar texture that divides the rock into parallel planar layers. It could be formed as primary or secondary structure. Secondary foliation is produced either by regional metamorphism by the effect of pressure and temperature (e.g. schists and gneisses) or by dynamic metamorphism by the effect of pressure only (e.g. mylonites).

## A- Classification of foliation based on the mode of origin:

- 1- primary foliation: it is primary in origin formed during the formation of the rock without the effect of secondary stresses (e.g. Platy flow structure at the margins of plutonic igneous rocks).
- 2- secondary foliation: formed after the rock consolidation by the effect of pressure and temperature.

## B- Geometric Classification of foliation based on its relation to bedding:

- 1- bedding foliation (cleavage): formed parallel to layering.
- 2- axial plane foliation (cleavage): formed parallel to the axial planes of folds
- 3- inclined foliation (cleavage): formed inclined to bedding and axial planes of folds.

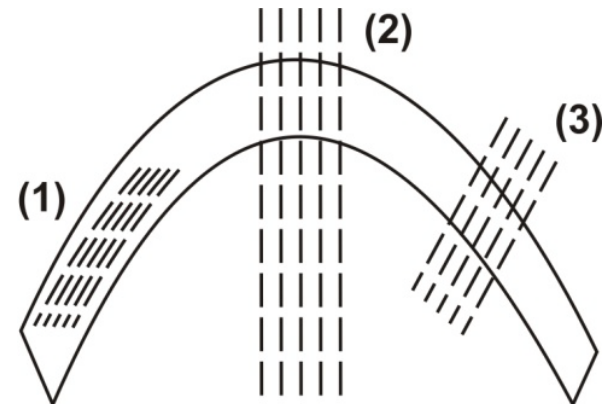

## C- Classification of foliation based on the internal fabric of the rock:

### 1- salty cleavage, schistosity, gneissosity:

Due to the preferred orientation of platy minerals.

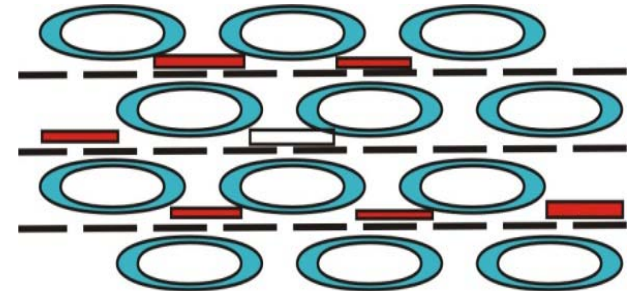

### 2- Fracture cleavage:

It is independent of the preferred orientation of minerals. It is closely spaced parallel fractures.

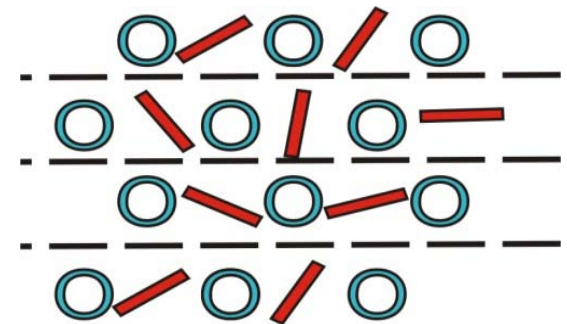

### 3- strain slip cleavage (crenulation cleav

Due to refolding of an early foliation usually on a minor scale





**Platey flow structure (primary foliation)**

**Foliation is discontinuous, and not extending through the whole rock**

Metamorphic rocks  
showing  
Bedding foliation





Anticlinal fold defined by the orientation  
of bedding foliation in the limbs



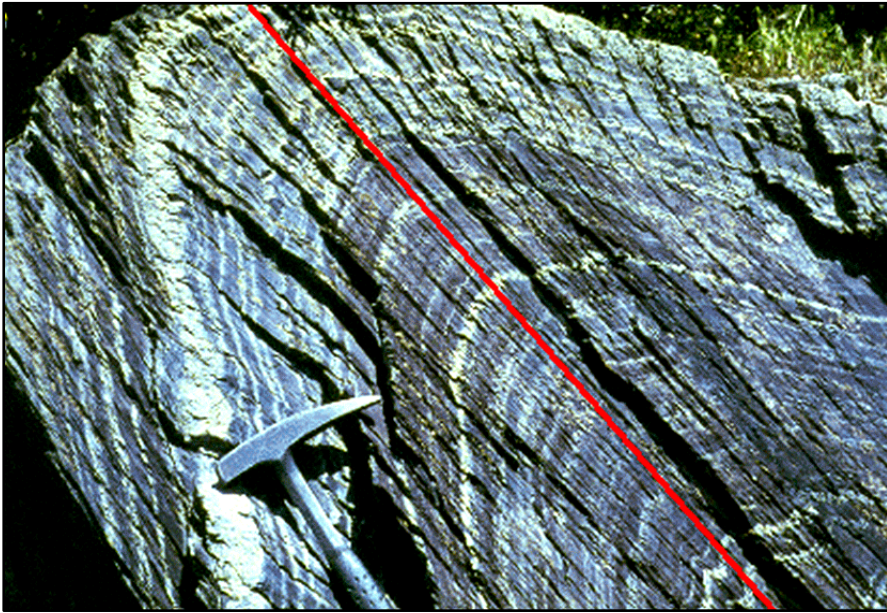

Axial plane cleavage

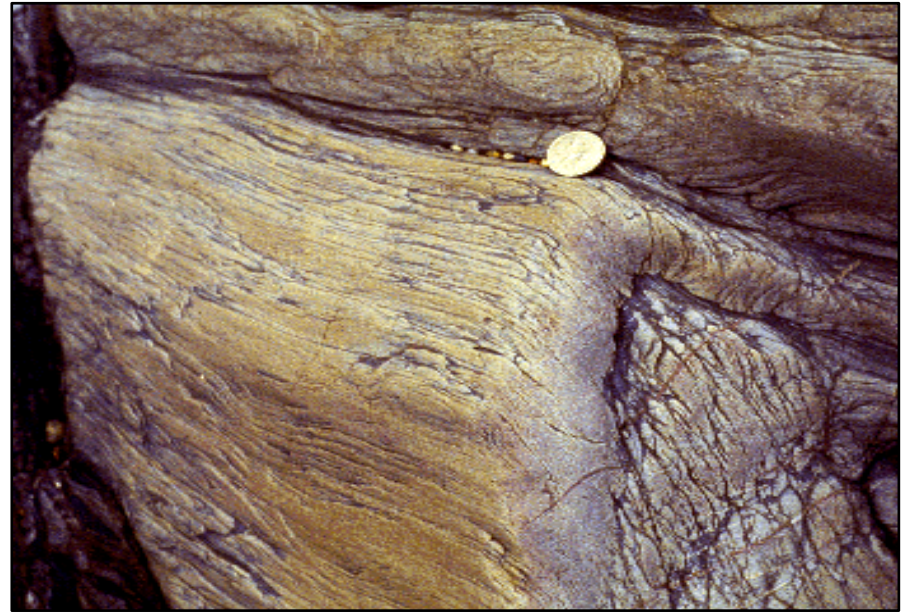

Fracture cleavage

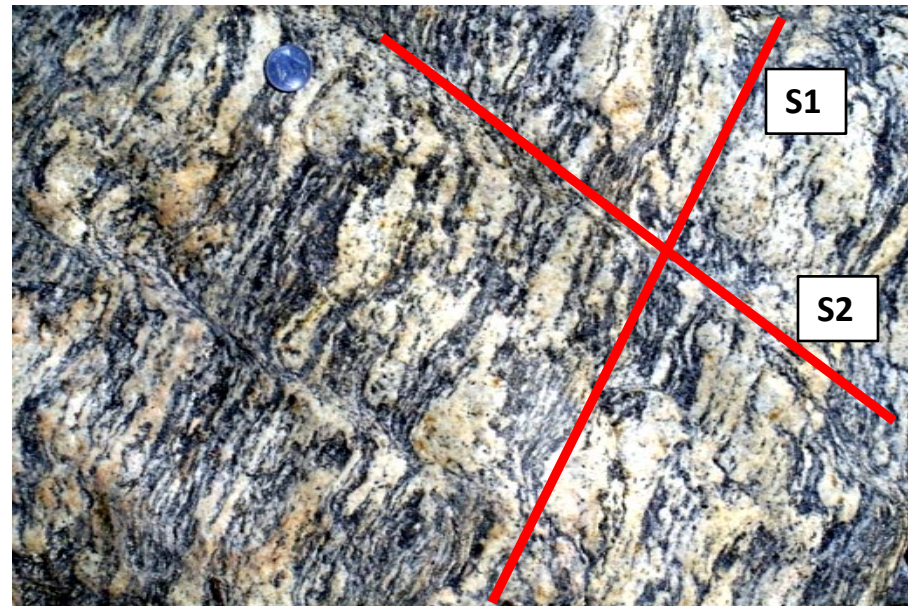

Strain slip cleavage

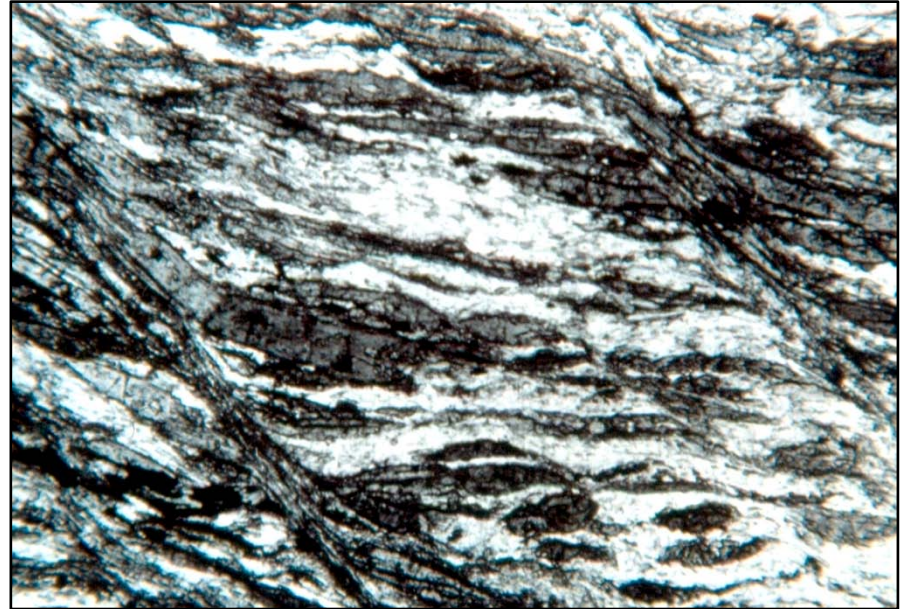
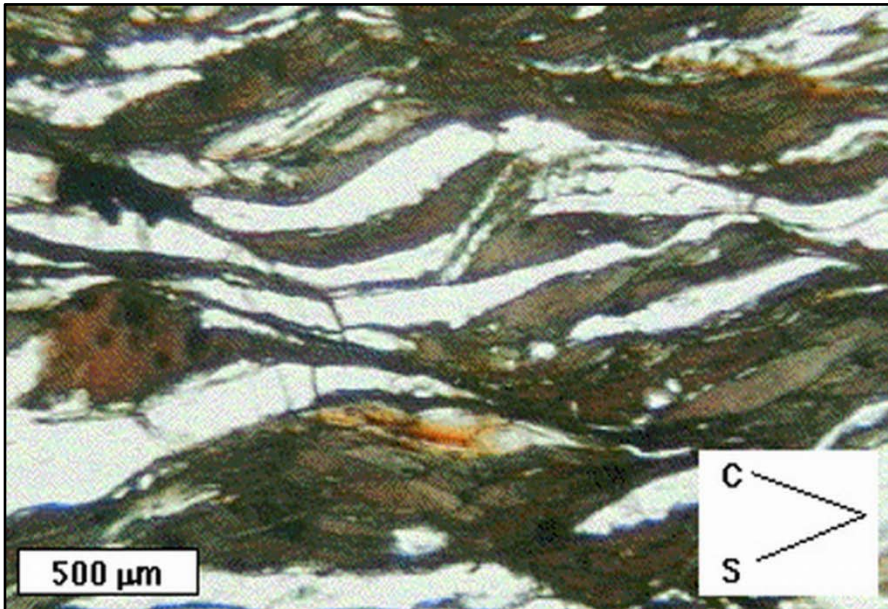
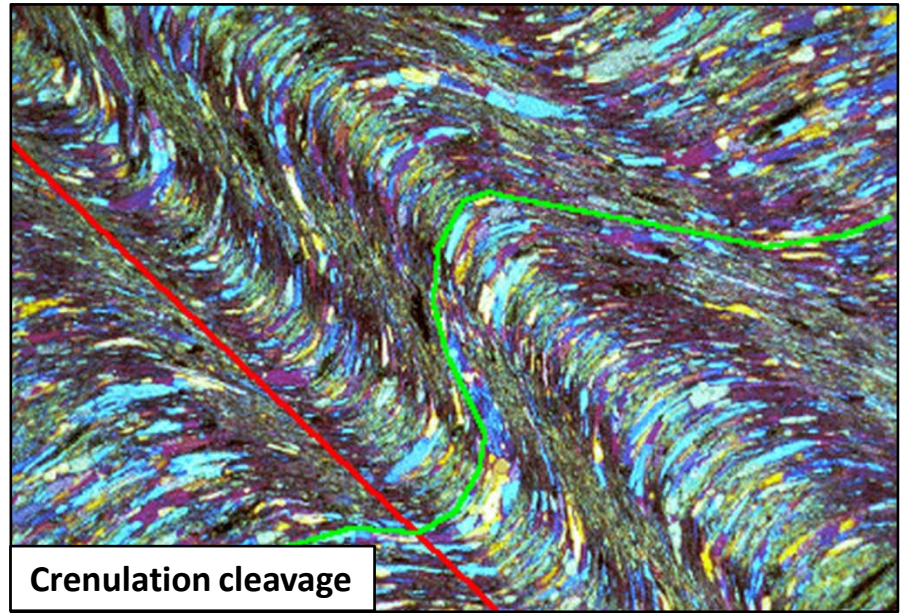

Strain slip cleavage



**Strain slip cleavage**

Based on the grade of metamorphism these rocks are termed: slates, schists or gneisses



# Lineation

Lineation is the parallelism of some linear property in the rock. It may be primary in origin (e.g. The linear flow structure in plutonic igneous rocks), or secondary due to deformation. Lineations as a linear feature are defined by its trend and angle of plunge.

## Types of lineations:

- 1- Mineral lineation: parallel arrangement of constituent minerals, such as hornblende and quartz.
- 2- Deformed conglomerate (stretched pebbles, stretched conglomerates). Due to intensive deformation, the conglomerate pebbles are stretched and elongated forming lineation.

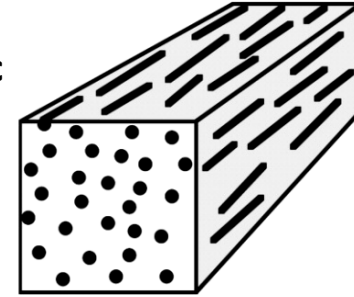

common minerals:

hornblende  
sillimanite  
feldspar  
quartz  
biotite

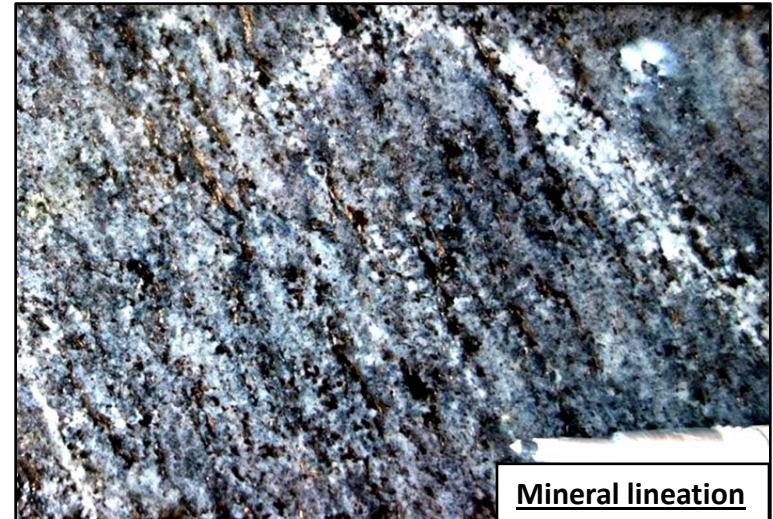

Mineral lineation



Deformed pebbles

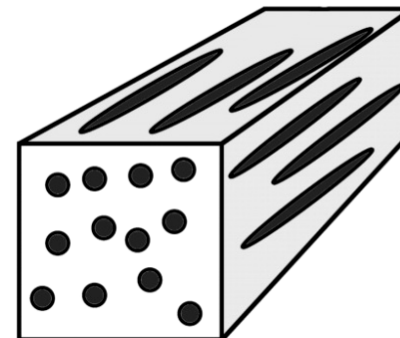

common features:

oids  
pebbles  
reduction spots

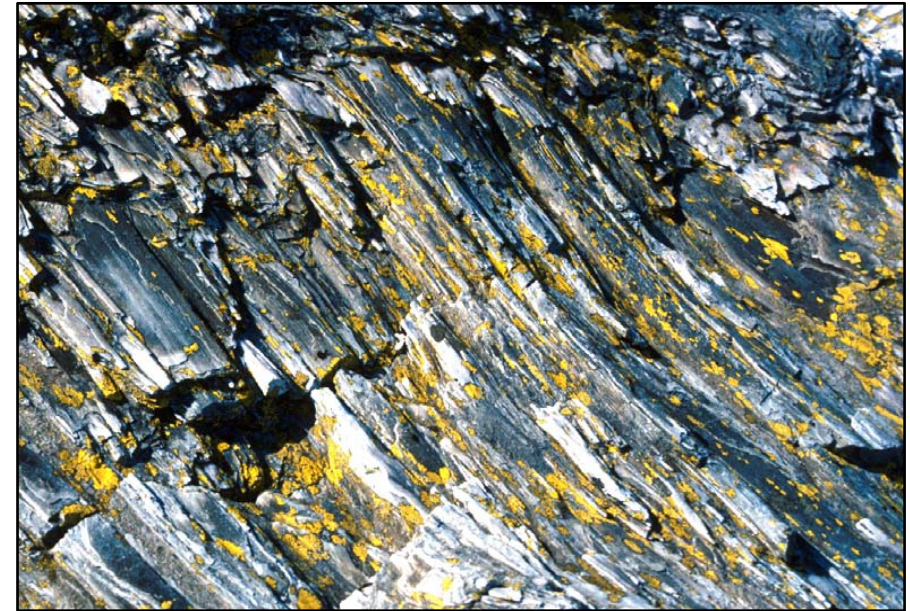

**Deformed pebbles (deformed conglomerate, stretched pebbles)**  
**Notice the increase in the intensity of deformation**

### 3- Parallel axes of drag folds and kink folds:

The parallel arrangement of axes of drag folds and kinks are considered as lineation and are very helpful in structural analysis of major folds.

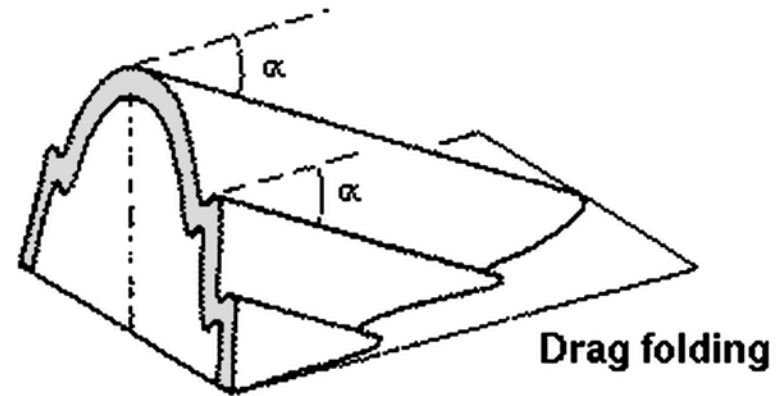

4- Boudinage structure: formed in competent beds (hard beds) when surrounded by incompetent beds (ductile beds). It is formed due to stretching along the limbs of folds normal to the fold axis. The competent layer is subdivided into stretched cylinders, meanwhile, the ductile beds fill in the gaps in between the cylinders. The axes of boudins (cylinders) are considered as lineation.

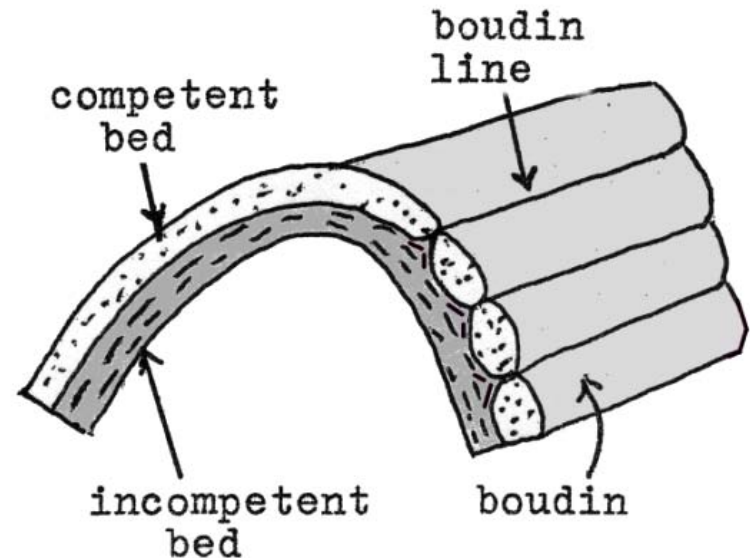
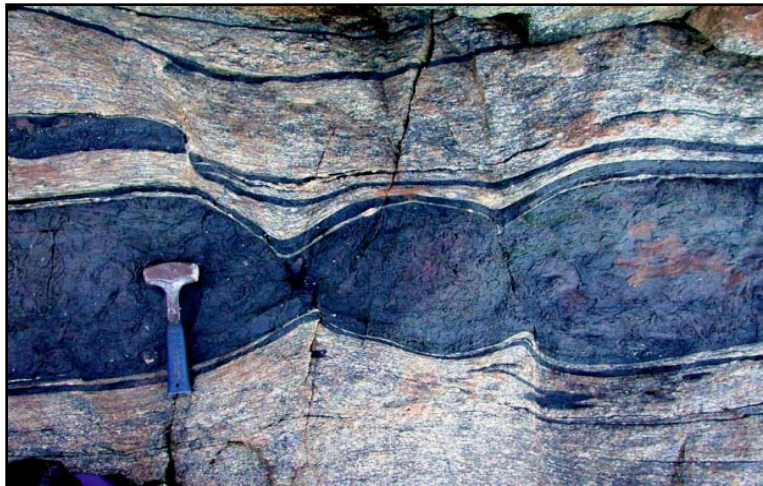

**Boudinage structure**



Kinking axes is a type of lineation



Boudinage structure is a type of lineation

**5- Lines of intersection of two planes:** The Parallel arrangement of the lines of intersection of two planes (eg. Axial plane cleavage and bedding) is considered as a lineation.

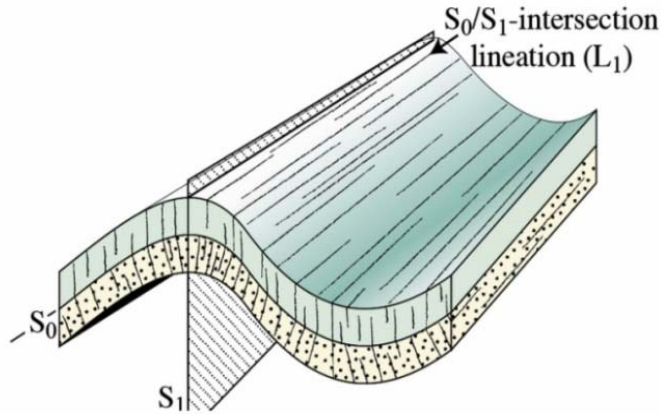

**Intersection of axial plane cleavage and bedding**

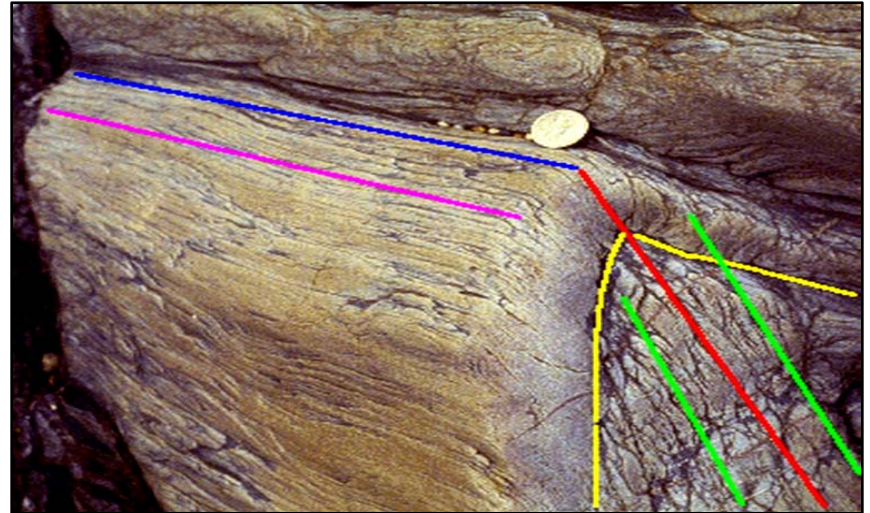

**6- Crenulation lineation:** are small crenulation formed on the foliation plane during folding normal to the applied stress.





Crenulation lineation

**7- Pencil structure:** is a pencil like structure formed due to the intersection of two foliation trends. It has a preferred orientation and form a lineation in low grade metamorphic rocks.



**8- Slickensides of faults:** it is formed along fault planes as scratches oriented parallel to the net slip movement along the fault. By using slickensides, you can determine the type of the fault whether it is dip slip, strike slip or oblique slip fault. It is commonly associated by **steps** (few millimeters in height) lying normal to the slickensides. These steps indicate the direction of slip in the two fault blocks. Accordingly, you can determine if the dip slip fault is normal or reverse, and the strike slip fault is right or left lateral.



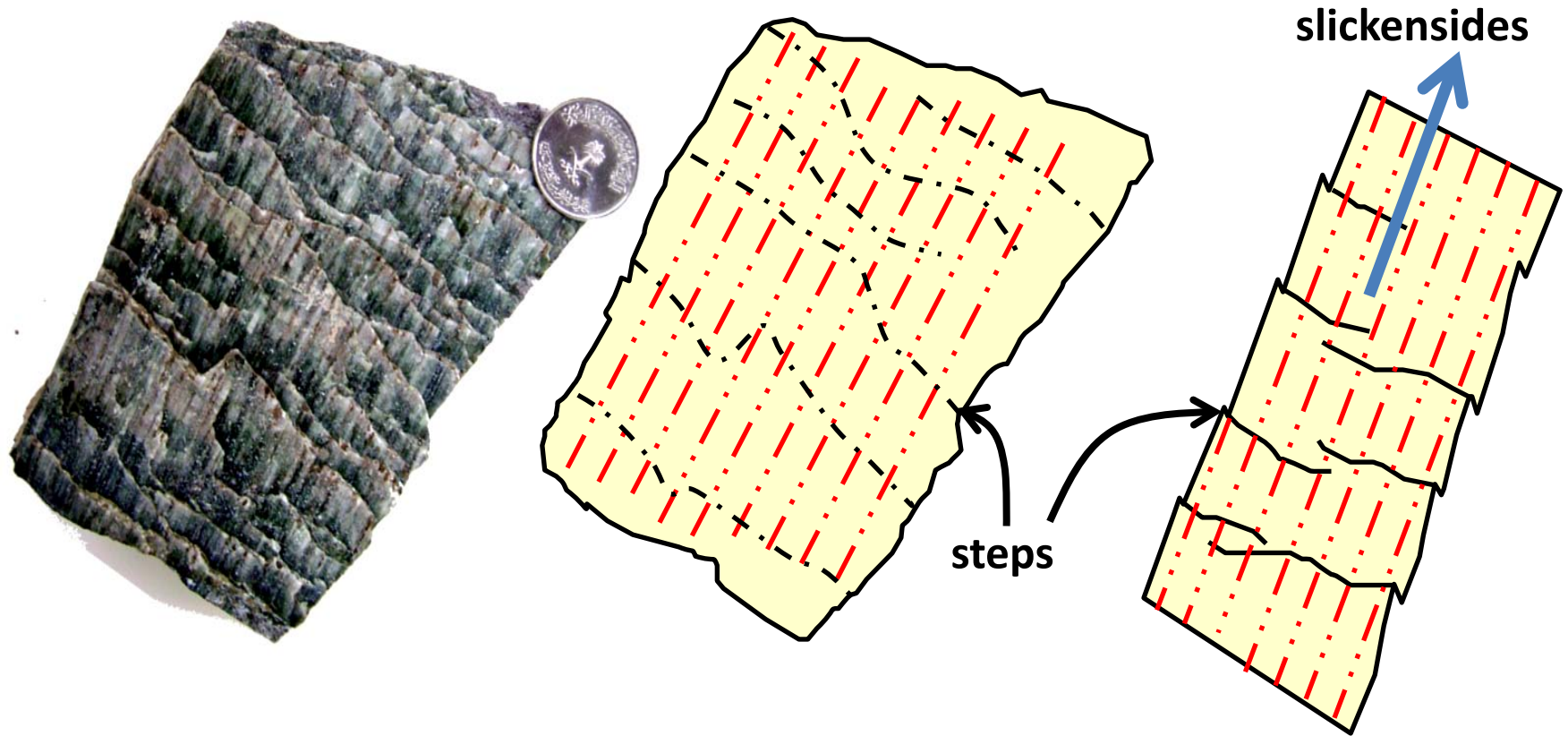

Slickensides and steps developed on a fault plane  
Slickensides indicate an oblique slip fault (oblique net slip).  
Steps indicate a reverse slip.  
The fault is an oblique reverse fault.

N.B.:

Some of the figures and photos used in this lecture are used after previous literatures for the purpose of teaching for students.